

Hybrid Renewable Energy Standalone Systems

AMBRISH CHANDRA

FIEEE, FCAE, FEIC, FIET, FIETE, FIE,

Distinguished lecturer IEEE Power and Energy Society

Distinguished lecturer IEEE Industry Application Society

Professor

Department of Electrical Engineering

Université du Québec

École de Technologie Supérieure

Montreal, Quebec, Canada

IEEE Distinguished Lecture

May/June, 2018

OUTLINE OF THE PRESENTATION

- ❖ **INTRODUCTION – GLOBAL WARMING, SITUATION IN NORTH CANADA AND QUEBEC**
- ❖ **OPTIMIZING THE USE OF DIESEL GENERATORS**
- ❖ **WIND AND SOLAR RADIATION PROFILES IN CANADA AND QUEBEC**
- ❖ **PROBLEMS RELATED TO RENEWABLE ENERGY SOURCES**
- ❖ **STAND ALONE WIND ENERGY CONVERSION SYSTEMS**
- ❖ **MICRO GRIDS IN HYBRID STANDALONE SYSTEMS**
- ❖ **DIFFERENT CONFIGURATIONS OF HYBRID ENERGY BASED STANDALONE SYSTEMS**
- ❖ **RENEWABLE ENERGY SOURCES-ECOLOGICAL ALTERNATIVE FOR ISOLATED MINING SITES**
- ❖ **CONCLUSIONS**

❖ INTRODUCTION

Global Warming

The world is on pace to set another high temperature benchmark, with 2016 becoming the third year in a row of record heat.

NASA scientists announced earlier that global temperatures in 2016 were much higher than in the first half of 2015. While the first six months of 2015 made it the hottest half-year ever recorded, “2016 really has blown that out of the water.”

Now 2017 is the second hottest year in record after 2016.

❖ INTRODUCTION

21st annual Conference of the Parties (COP) in Paris from November 30th to December 11th 2015

On 12 December 2015, 196 Parties to the UN Framework Convention on Climate Change (UNFCCC) adopted the **Paris Agreement**, a new legally-binding framework for an internationally coordinated effort to tackle climate change.

Keeping the rise in temperature below 2°C above pre-industrial levels: Scientists believe that a greater increase in temperature would be very dangerous. The agreement even establishes, for the first time, that we should be aiming for 1.5°C, to protect island states, which are the most threatened by the rise in sea levels. Studies show that with the present rate global warming would be between 2.7°C and 3°C, i.e. above the threshold set by scientists.

In the first half of 2016 average temperatures were about 1.3 °C above the average in 1880, when global record-keeping began.*

*<http://www.nytimes.com/2016/07/20> consulted on 28 November 2016

❖ INTRODUCTION

21st annual Conference of the Parties (COP) in Paris from November 30th to December 11th 2015

The agreement acknowledges that \$100 billion (in loans and donations) will need to be raised each year from 2020 to finance projects that enable countries to adapt to the impacts of climate change (rise in sea level, droughts, etc.) or reduce greenhouse gas emissions.

The contribution that each individual country should make in order to achieve the worldwide goal are determined by all countries individually and called "nationally determined contributions" (NDCs). The contributions should be reported every five years and are to be registered by the UNFCCC Secretariat.

❖ INTRODUCTION

21st annual Conference of the Parties (COP) in Paris from November 30th to December 11th 2015

Notably China, the United States and Russia, the countries with three of the largest greenhouse gas emissions are the signatories of the agreement, with percentage of greenhouse gases of 20.09%, 17.89% , and 7.53%, respectively. (EU 9%, India 4.10%, Canada 1.95%, Mexico 1.7%, UK 1.55%, Ecuador 0.67%, Morocco 0.16%, Ireland 0.16%, Algeria 0.5%, Tunisia 0.07%, Egypt 0.61%, Nepal 0.08%, Bhutan 0.00%).

But last year US president Mr. Donald Trump has withdrawn from the agreement.

https://en.wikipedia.org/wiki/List_of_parties_to_the_Paris_Agreement Consulted May 23 2018

❖ INTRODUCTION

• Situation in North Canada and Quebec



Making Igloo: An igloo is basically a dome of ice cubes and snow. Inuits use snow to make their homes because the air pockets in the snow act like isolation. An Inuit man can build an igloo in about one hour. Out side an igloo temperature varies at about -45°C and inside the temperature varies between around -7°C to around 16°C when the only source of heat is body heat.



❖ **INTRODUCTION**

- **Situation in North Canada and Quebec**



❖ **INTRODUCTION**

- **Situation in North Canada and Quebec - use of diesel generators (DG)**



Remote village



Water pumping station



Mine for extraction iron in SCHEFFERVILLE in Canada



Communication station



Petroleum station



Island

❖ INTRODUCTION

• Situation in North Canada and Quebec - use of diesel generators (DG)

Currently, all these facilities based on DG use oil as a primary energy source. This source of energy is inefficient, costly and responsible for the emission of greenhouse gases (GHGs). With high fuel prices and high transportation costs, financial losses are colossal .

Barrels
of fuel

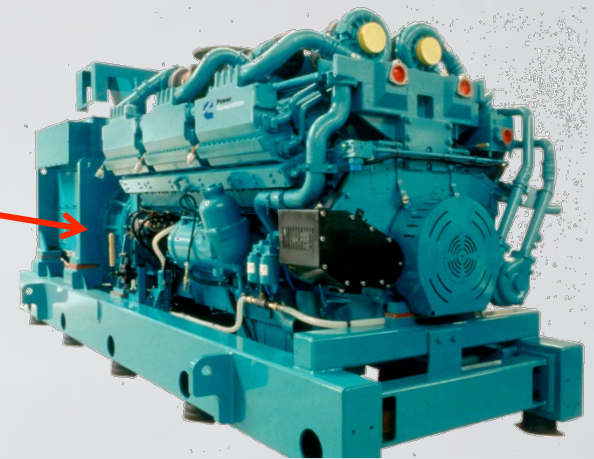

Remote villages use Diesel Generators as energy source.

Diesel Generator .

❖ INTRODUCTION

• Situation in North Canada and Quebec - use of diesel generators (DG)

- With high fuel prices and increase in transportation costs, financial losses are enormous. For example, Hydro-Quebec estimated at more than \$ 133 million expenditure to power 14,000 subscribers in the isolated communities which are not connected to the main grid [1].
- According to Hydro-Quebec, 140,000 tones of greenhouse gases emits due to the use of DGs in remote areas of Quebec [1].

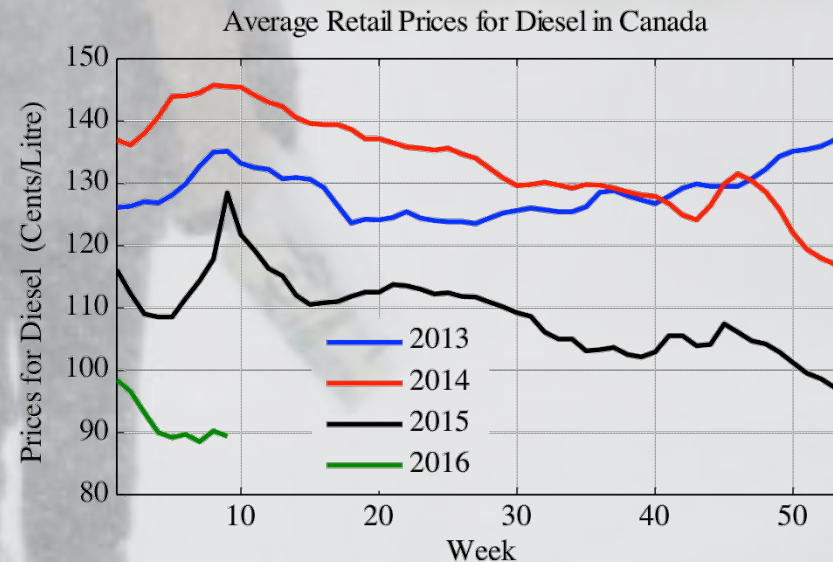

Fuel prices [2].

[1] P. Raphals, S. Krohn, M. Tampier, Technologies permettant de réduire l'utilisation du diesel dans les territoires des réseaux autonomes d'Hydro-Québec, Rapport Préparé pour Hydro-Québec, 15 mai 2006.

[2] <http://marketrealist.com/2014/11/fuel-prices>

❖ INTRODUCTION

- Situation in North Canada and Quebec - use of diesel generators (DG)

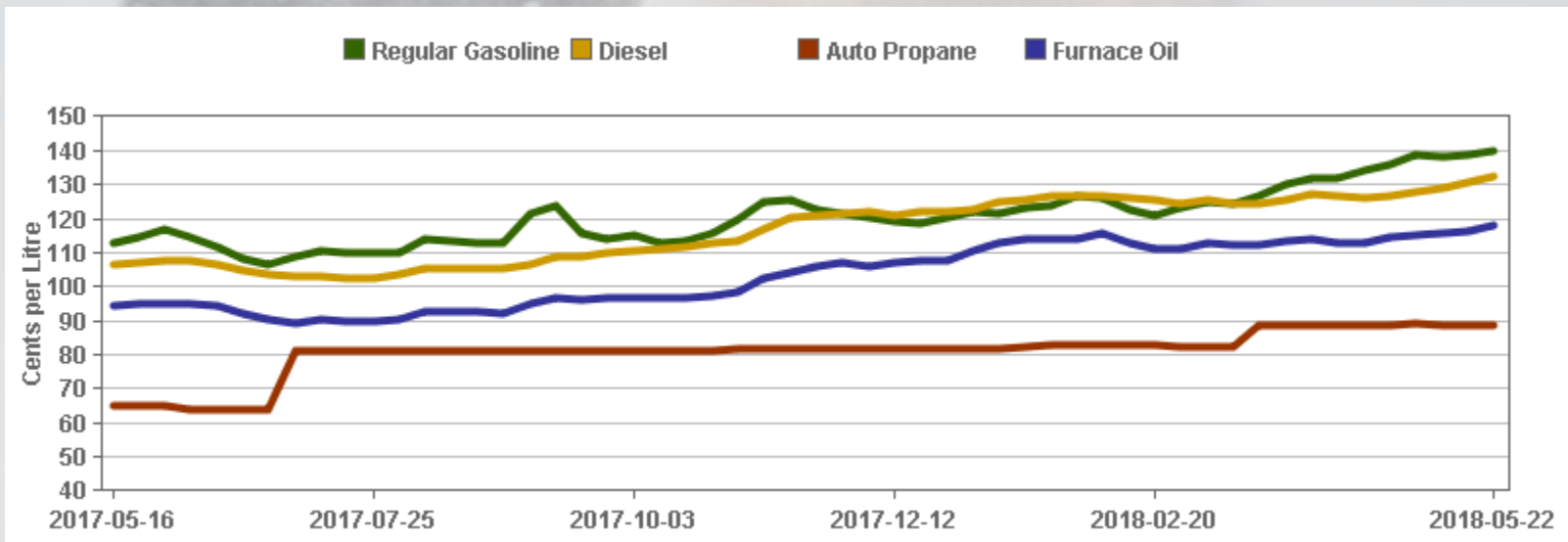

http://www2.nrcan.gc.ca/eneene/sources/pripri/prices_byfuel_e.cfm?locationName=Canada#priceGraph Consulted on 22 May 2018

❖ INTRODUCTION

- **Situation in North Canada and Quebec - use of diesel generators (DG)**
- According to Hydro-Quebec, the estimated cost for new power lines installations is approximately \$1M / km [1].
- Based on current projections, the power needs of these isolated areas will reach near to 155 MW by the year 2018. It will result in the total electricity production using these DGs for isolated communities to approximately 300 GWh / year [1].
- For example, in Ontario, the cost of producing off-grid electricity using diesel can be up to 10x higher (up to 94 cents/kWh) than the cost of electricity within the primary electricity grid [2].
- The annual cost of funding diesel generation in Ontario's remote communities is estimated at \$90 million annually (fuel cost, operation and maintenance, transportation, capital expenditure)[2].

[1] P. Raphals, S. Krohn, M. Tampier, Technologies permettant de réduire l'utilisation du diesel dans les territoires des réseaux autonomes d'Hydro-Québec, Rapport Préparé pour Hydro-Québec, 15 mai 2006.

[2] Advanced Energy Centre (advancedenergycentre@marsdd.com); Consulted 08/03/2016



INTRODUCTION

- **Situation in North Canada and Quebec - use of diesel generators (DG)**

There are two different types of DGs

1. Fixed Speed DGs:

Advantages:

Simplicity

Mature technology

Drawbacks:

Runs under light load for long time:

high cost of electricity

air and noise pollution

loss in fuel efficiency and

increased operation and maintenance cost

2. Variable Speed DGs:

Advantages:

Reduced fuel consumption

increased conversion efficiency

❖ OPTIMIZING THE USE OF DIESEL GENERATOR

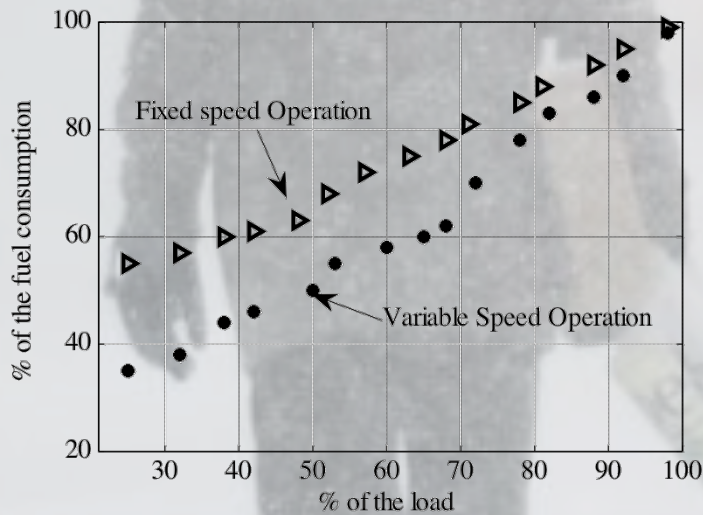

Fuel consumption for variable and fixed speed operation of DG [1]

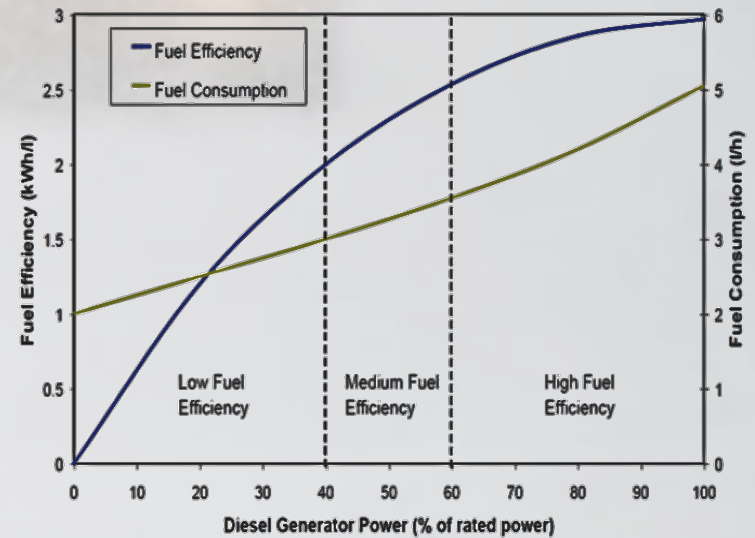

Fixed speed DG characteristic[2].

[1] R. Pena, R. Cardenas, J. Proboste, J. Clare, and G. Asher, "Wind-Diesel Generation Using Doubly Fed Induction Machines," Energy Conversion, IEEE Transactions on, vol. 23, pp. 202-214, 2008.

[2] DLRE Renewable Energy Solution <http://www.dailylife.com.sg/page6.html>

❖ WIND PROFILE IN CANADA

- Quebec, also has a strong wind profile in several places [1]. The wind profile could be used to drive wind turbine to produce electricity. According to [1], the density of wind energy varies between 0 to 1000 W/m² and the wind speed varies in between the range of 3 to 10 m / s.

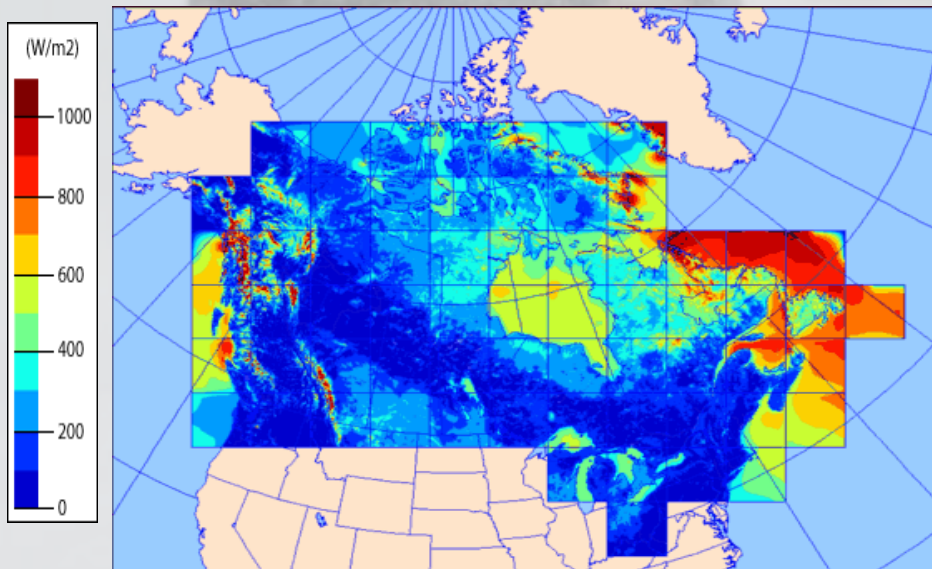

Average wind power per year[1].

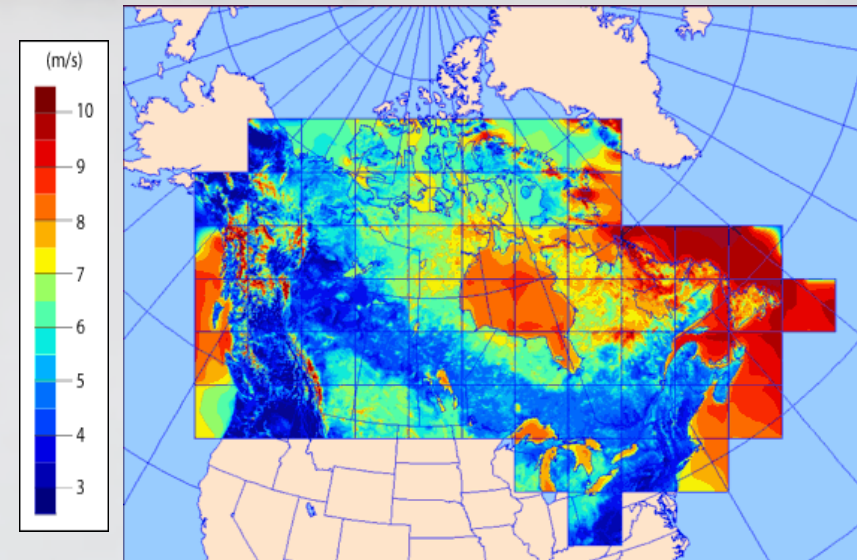

Average wind speed per year[1].

❖ SOLAR RADIATIONS IN CANADA

- According to Greenpeace Canada solar energy received by only 0.1% of Quebec's territory would be theoretically required to generate all the energy Quebec needs annually.

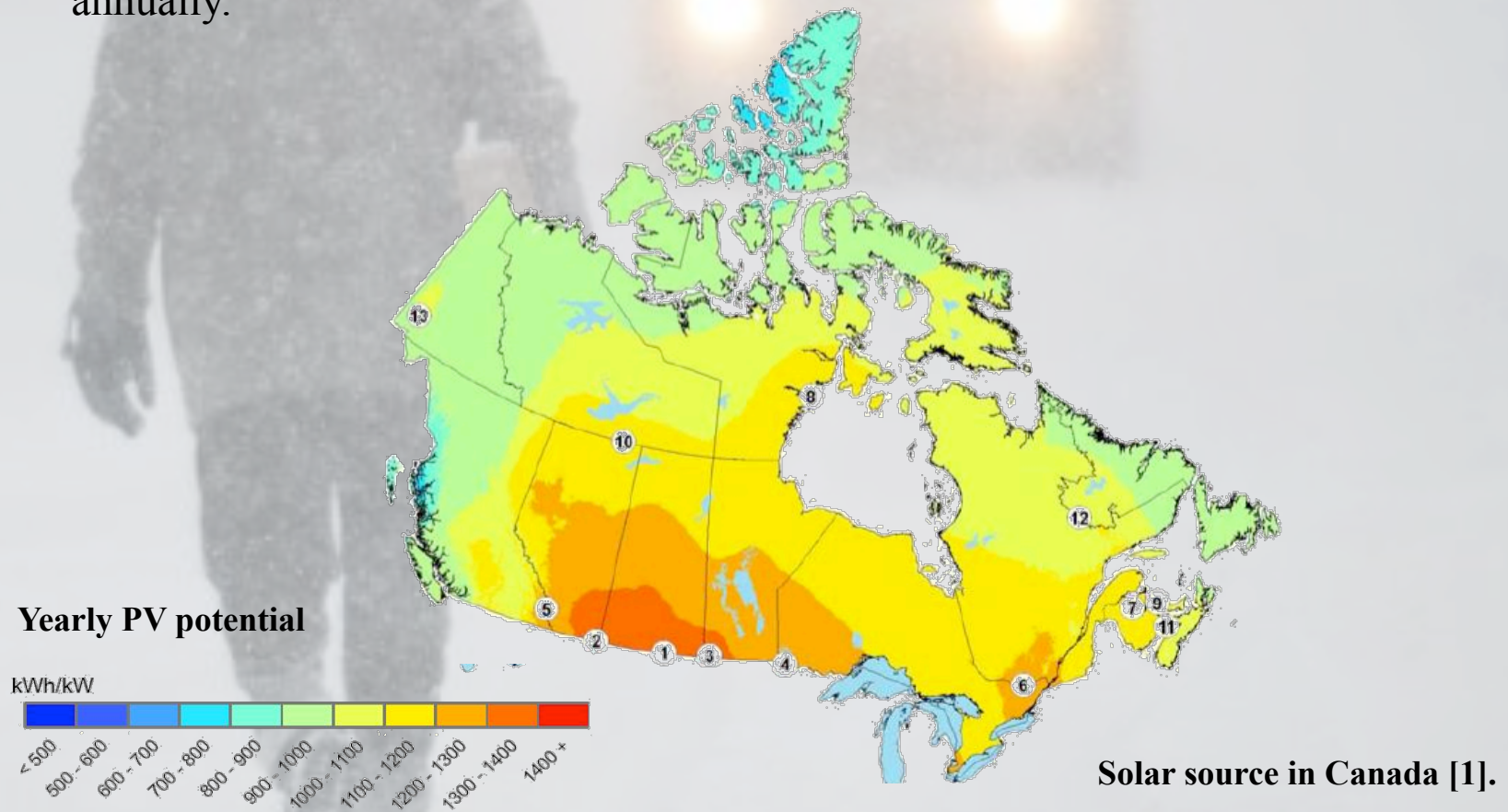

❖ Wind Energy In Canada

- **Installed capacity**

In December of 2017, Canada surpassed the 12,000 MW threshold, placing it seventh in the world for installed capacity. Today, wind energy supplies approximately 4 per cent of Canada's electricity demand with enough power to meet the needs of over 2.5 million Canadian homes [1].

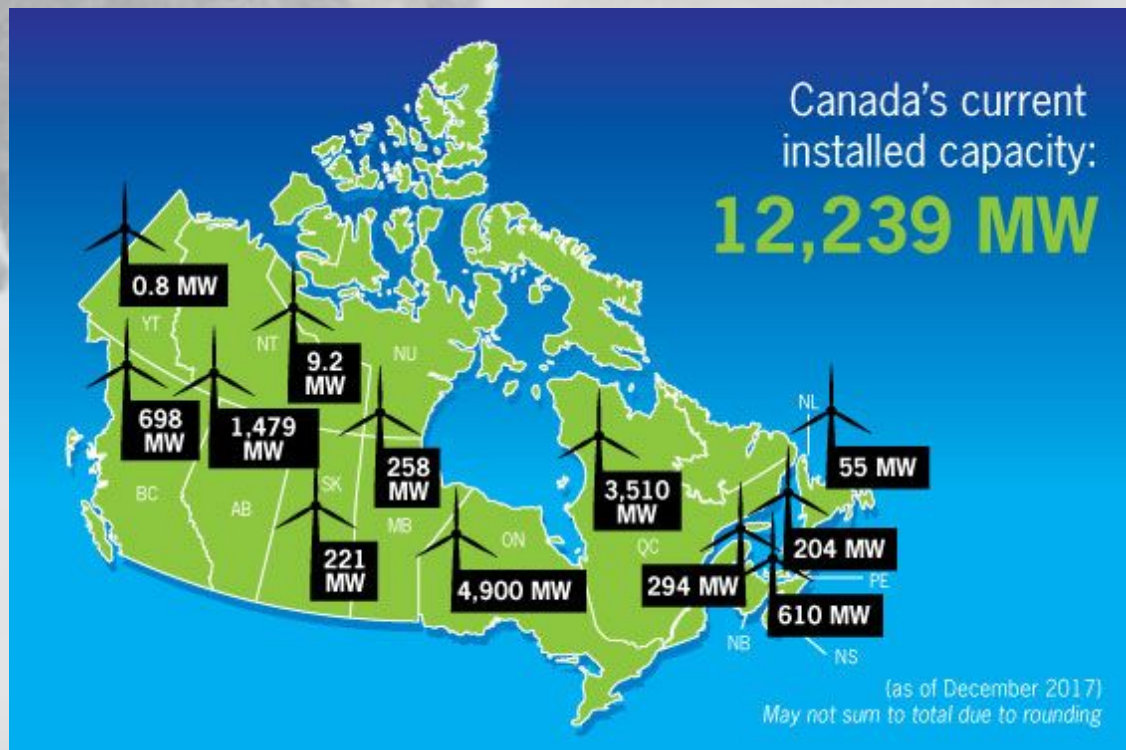

❖ Solar Energy In Canada

- **Installed capacity**

Canada's current
Installed capacity
1843.18 MW, 2015

2662 MW in 2016

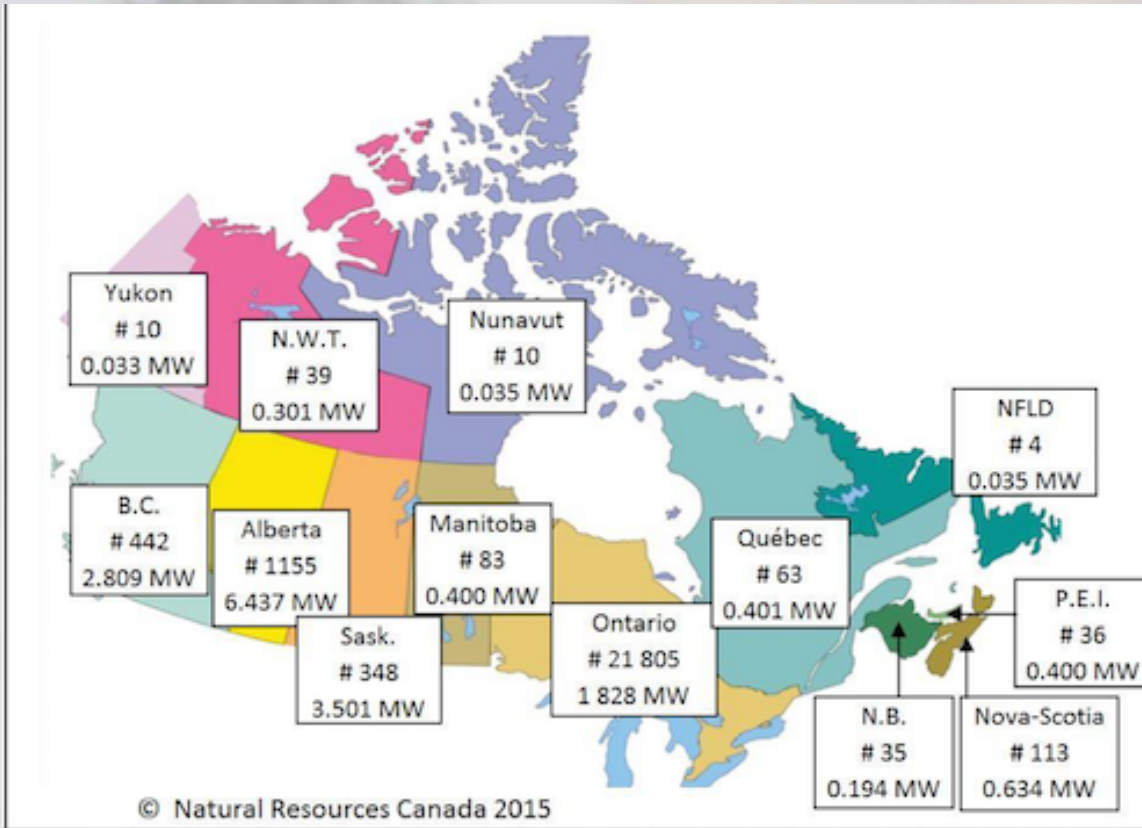

Map showing the Canadian provinces, the capacity (megawatt) and the number of utility interconnected PV Systems in 2015[1]

❖ PROBLEMS RELATED TO RENEWABLE ENERGY SOURCES

• Problems related to the intermittence of the renewable energy sources

1. Temperature, humidity, altitude, topography, atmospheric pressure, and other factors have an impact on the wind speed. Thus, the quality of the predictions of the power produced by a wind turbine is highly dependent on the prediction of wind speed.
2. Wind speed is fluctuating and unpredictable. Most of the time, load demand does not match with available wind profiles and therefore does not match with wind produced power.
3. The problem with photovoltaic is that the output power of the PV depends on the sun, weather and temperature of the cell, making it an uncontrollable source. Moreover, it is not available at night.

❖ PROBLEMS RELATED TO RENEWABLE ENERGY SOURCES

- **Renewable Powers need processing using Power Electronics Converters before being fed to consumers**
 1. The energy supplied by renewable energy sources needs a DC or AC conversion before being injected to the micro-grid, because consumer needs regulated voltage and frequency.
 2. The use of these power converters reduces the efficiency of the installation.
 3. On the other hand, **power electronic converters have multifunctional capabilities. Therefore, they can help to improve power quality on the distribution network.**

 - **Maximization of the electrical energy produced by renewable energy sources**
 1. Maximizing the use of renewable resources requires complex technology, advanced control systems and often a storage system.
-

❖ DESIRABLE CHARACTERISTICS OF THE ELECTRICAL MACHINES FOR RENEWABLE ENERGY

1. High efficiency over wide torque and speed ranges so as to increase the utilization of extractable energy;
 2. High power density so as to reduce the overall size and weight;
 3. Wide speed range so as to harness the energy at different speeds;
 4. High reliability so as to reduce the operational failure or fault;
 5. Maintenance free so as to eliminate the maintenance cost and possible outage for maintenance;
 6. High robustness so as to withstand harsh operation conditions and natural environment;
 7. Good voltage regulation so as to maintain the system voltage;
 8. High power factor so as to enhance the power transfer;
 9. Low cost so as to reduce the system cost .
-

❖ EXISTING MACHINES FOR RENEWABLE ENERGY

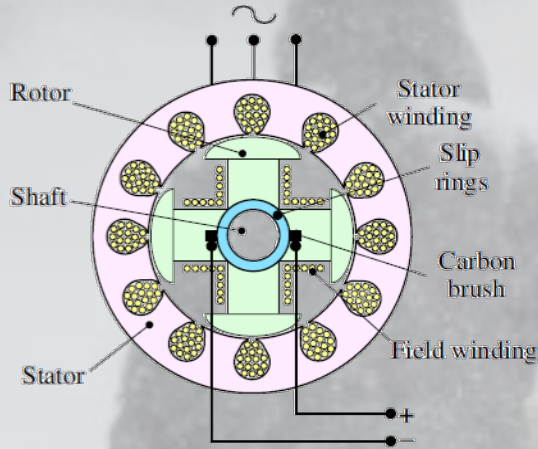

Wound-rotor Synchronous Generator

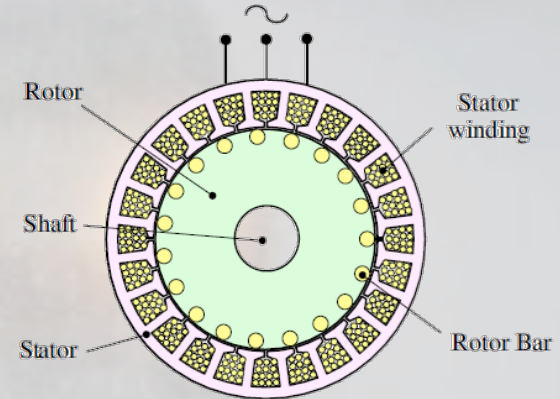

Squirrel-Cage Induction Generator

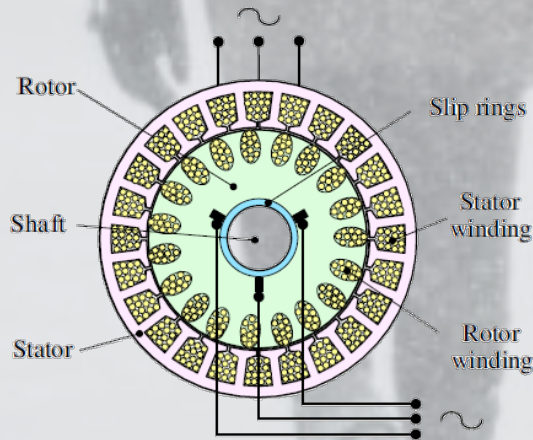

Doubly Fed Induction Generator

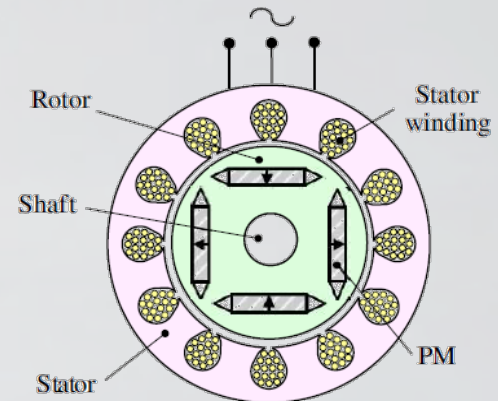

PM Synchronous Generator

❖ EXISTING MACHINES FOR RENEWABLE ENERGY

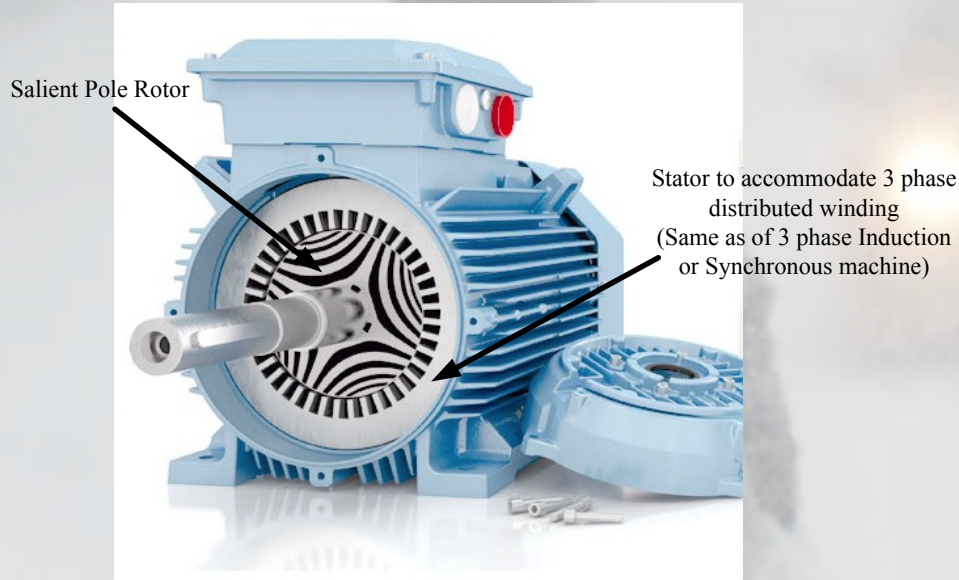

Synchronous reluctance machine

Sy RG :

- 1) Capacity available 30 kW – 300 kW
- 2) Stator is same as that of any 3 phase Induction or Synchronous machine.
- 3) Rotor is salient pole construction. Saliency is created by flux barriers or high reluctance path (q axis).
- 4) Robust construction.
- 5) Less losses than IG as rotor rotates at synchronous speed, thus rotor currents are negligible.
- 6) Rotor is completely magnet free.
- 7) Procedure of voltage buildup is same as in SEIG. External capacitor is required at stator terminals for voltage buildup as in SEIG.

Wind Energy Exploitation Technologies

Type A

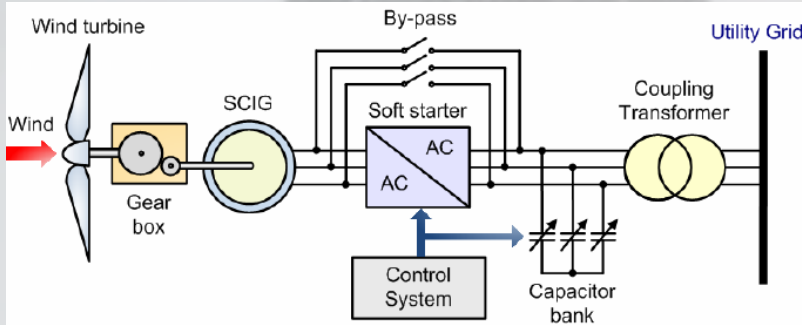

Type B

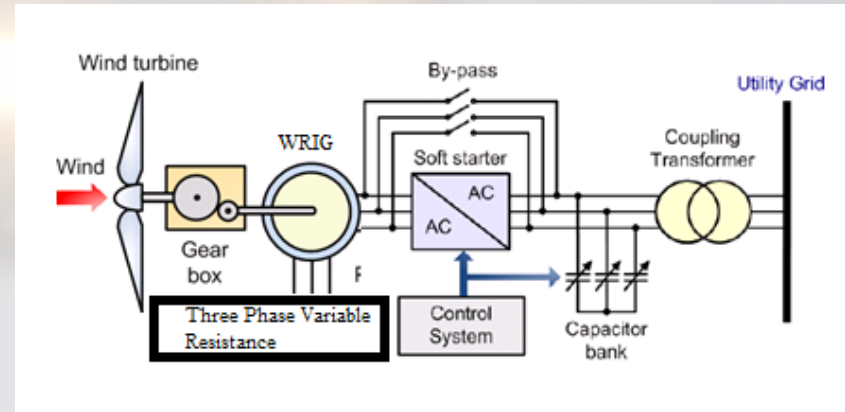

Type C

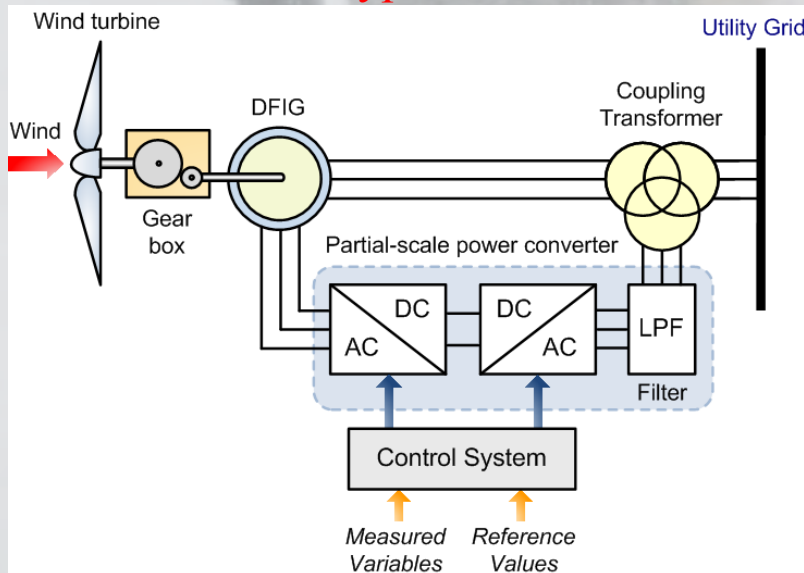

Type D

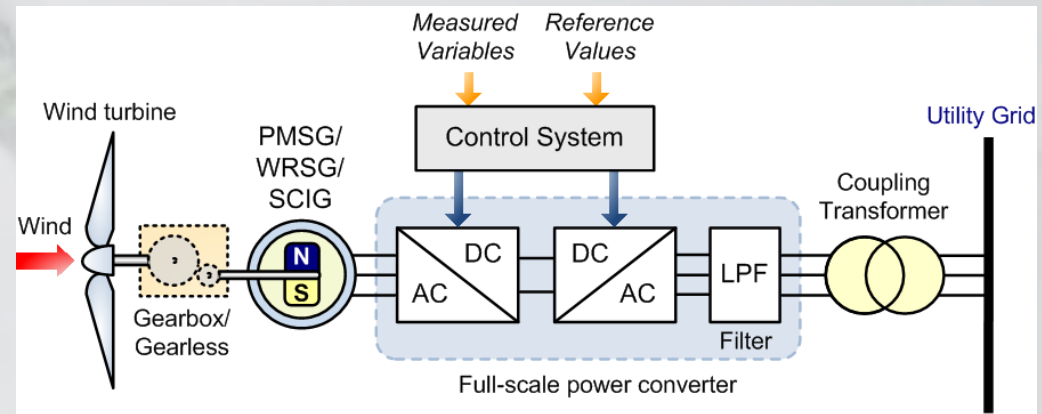

❖ HYBRID STANDALONE POWER GENERATION SYSTEMS

1. AC standalone micro-grid

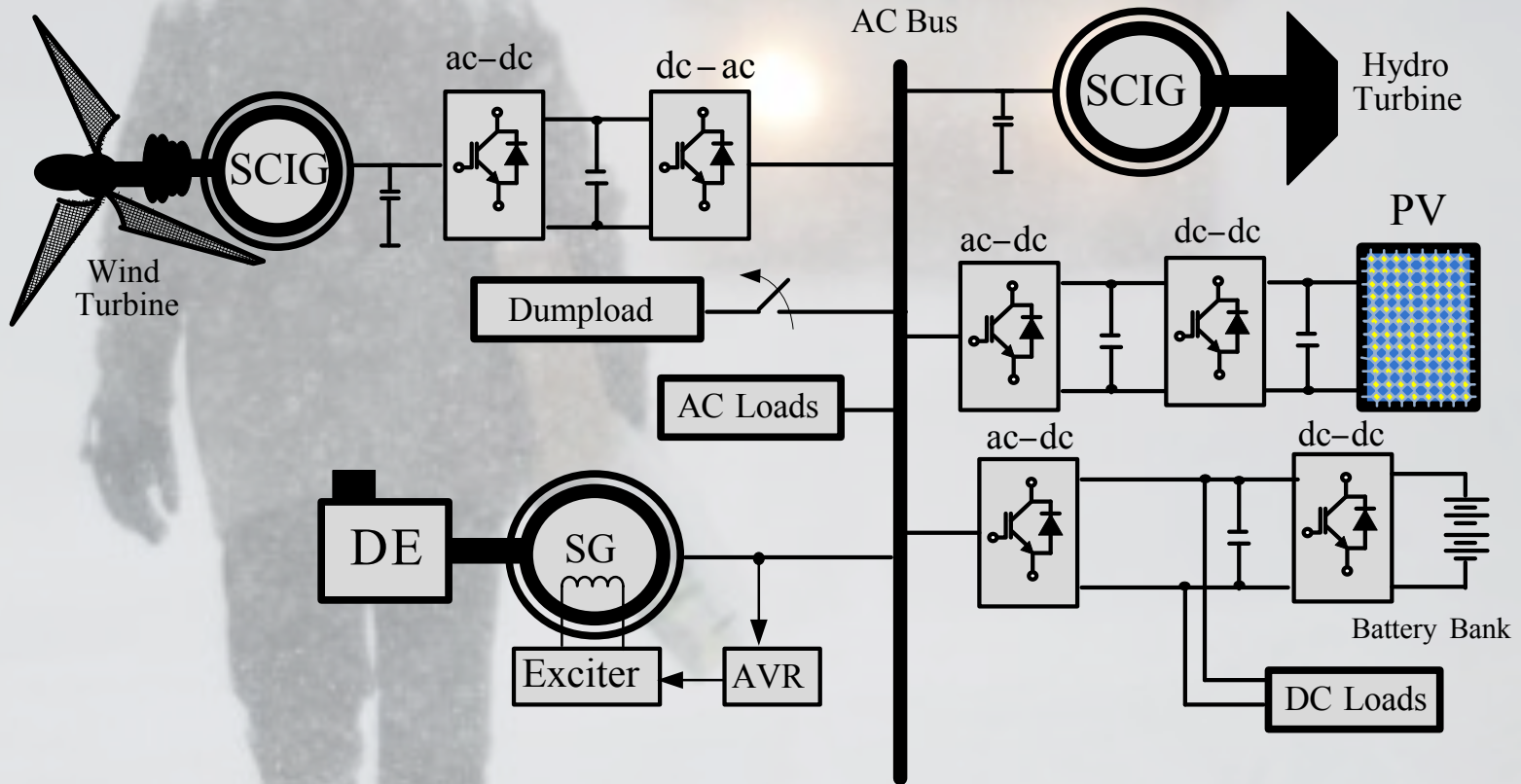

AC Standalone micro-grid

❖ HYBRID STANDALONE POWER GENERATION SYSTEMS

2. DC standalone micro-grid

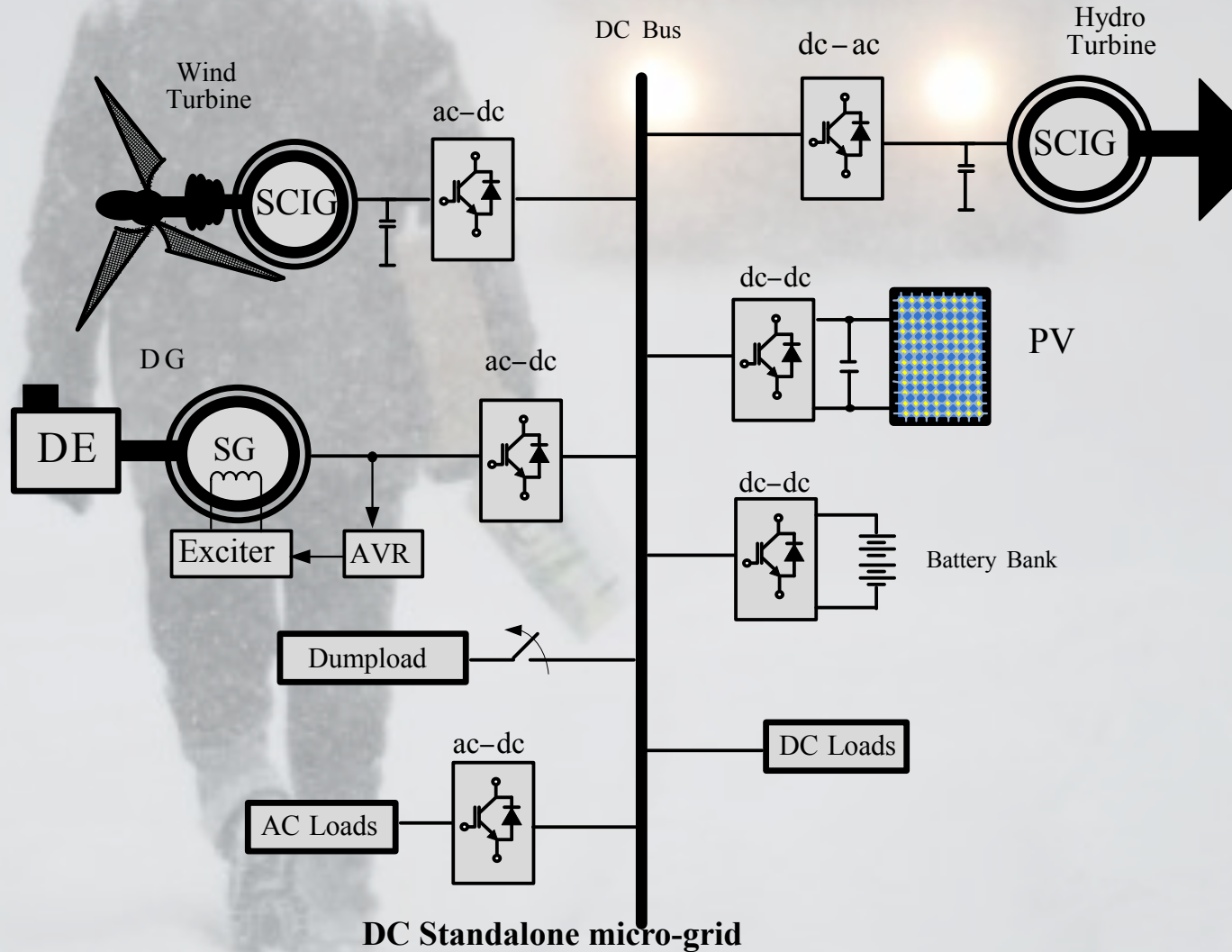

❖ HYBRID STANDALONE POWER GENERATION SYSTEMS

3. Hybrid AC-DC standalone micro-grid

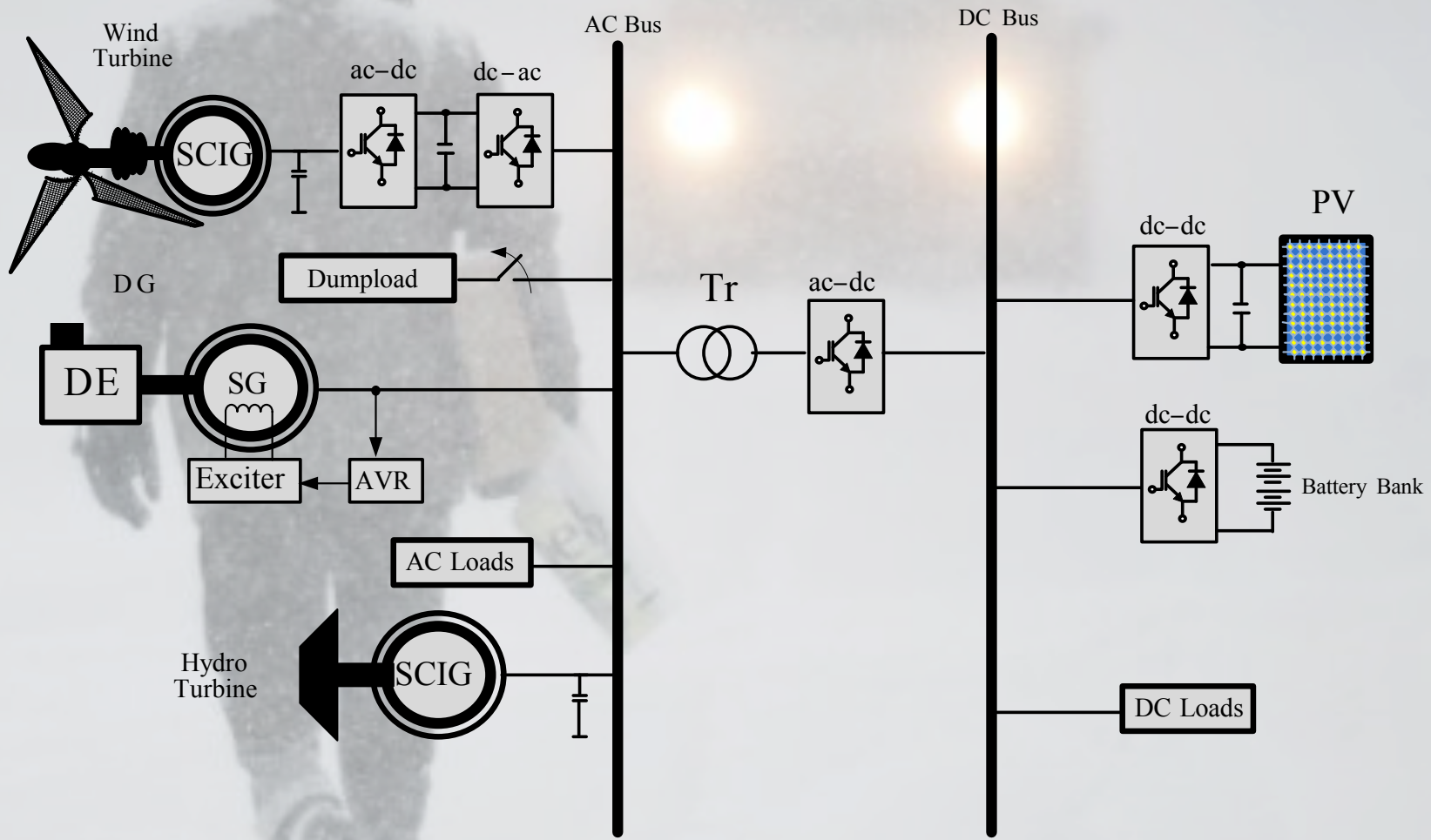

Hybrid AC-DC Standalone micro-grid

❖ COMPARISON BETWEEN AC AND DC MICRO-GRIDS

- **Advantages of AC standalone micro-grid**

1. Utilizing existing AC grid technologies and off the shelf products;
2. Well established protections and standards.

- **Disadvantages of AC standalone micro-grid**

1. Synchronization;
 2. Stability;
 3. Need for reactive power is inherent demerit;
 4. Power quality problems.
-

❖ COMPARISON BETWEEN AC AND DC MICRO-GRIDS

• Advantages of DC standalone micro-grid

1. All disadvantages of AC standalone micro-grids are not present
2. Most environment-friendly DGs, such as photovoltaic, fuel cells and variable speed wind power systems, generate DC power and most digital loads require DC power;
3. It can eliminate DC/AC or AC /DC power conversion stages required in AC standalone micro-grids for the above renewable energy sources and loads;
4. There are advantages
 - in terms of efficiency, because of less power conversion;
 - in cost and size of the system.

• Disadvantages of DC standalone micro-grid

1. Need further investigations on the proper operating range of DC voltage and protection apparatus for DC circuits.

❖ COMPARISON BETWEEN AC AND DC MICRO-GRIDS

• Advantages of Hybrid AC/DC standalone micro-grid

1. Many distributed energy resources, such as photovoltaic systems, generate power in DC form.
2. Many of the modern electrical loads, as well as energy storage systems, are either internally DC or work equally well with DC power and connect to the AC systems through converters.
3. Thus, application of hybrid AC/DC micro-grid allows the elimination of many AC-DC and DC-AC conversion stages, which would in turn result in considerable decrease in component costs and power losses, and increase in reliability.
4. Power quality issues, such as harmonics distortions and unbalances, are not present in these kind of micro-grid [1].

• Disadvantages of hybrid AC/DC standalone micro-grid

1. Energy management, control, and operation of a hybrid grid are more complicated than those of an individual AC or DC grid [1].

❖ POSSIBLE TOPOLOGIES IN HYBRID STANDALONE POWER GENERATION SYSTEMS

- Topologies based on fixed speed DG and variable speed WT coupled to the DFIG

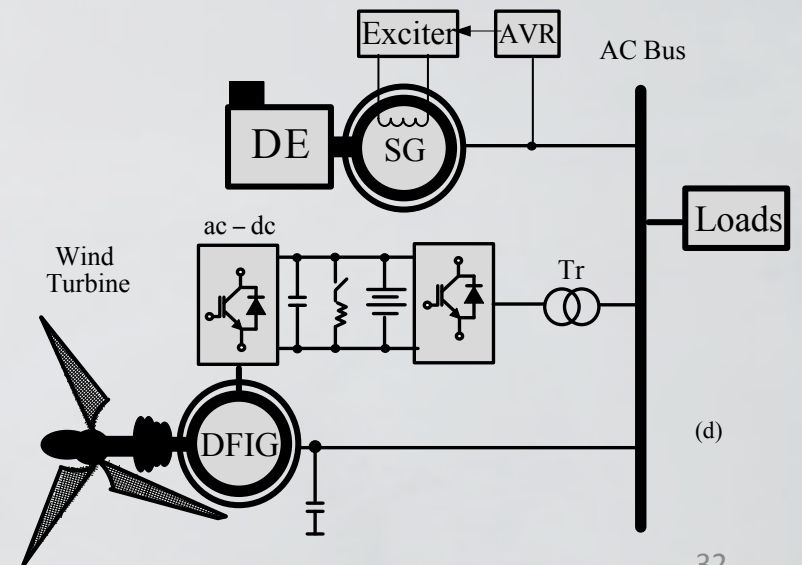
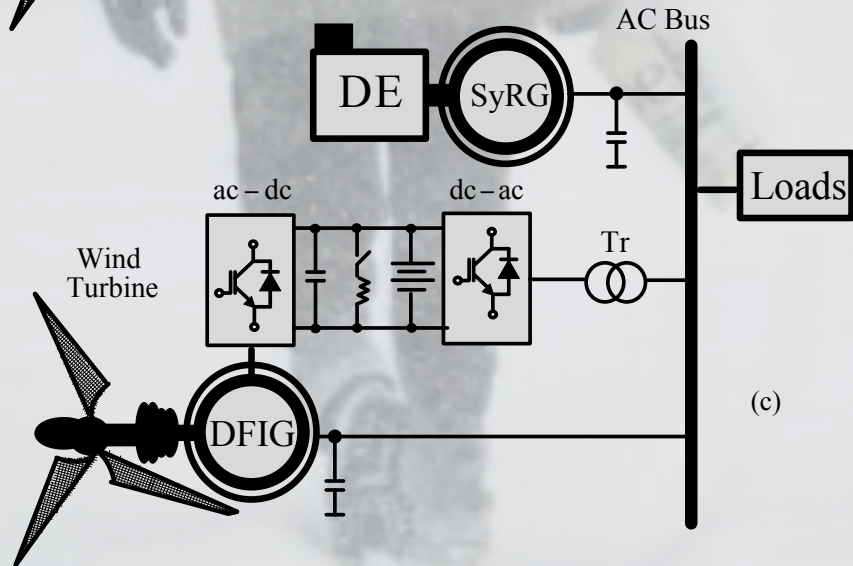
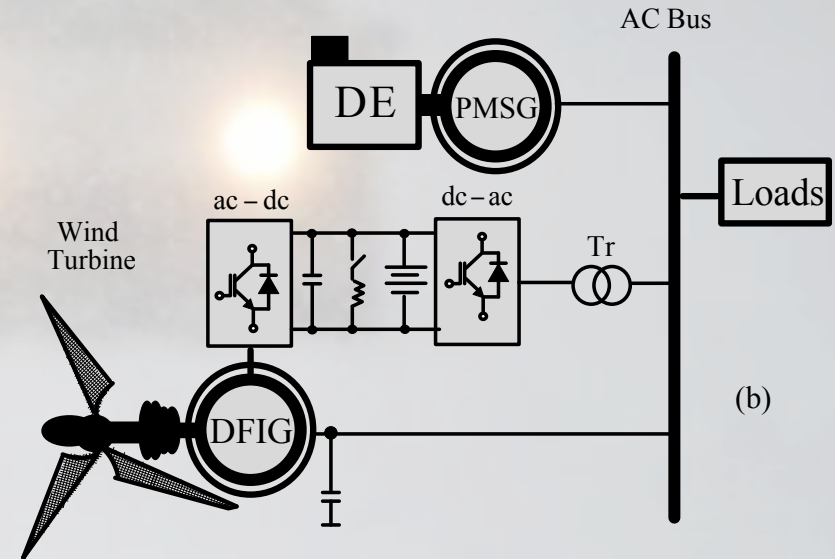
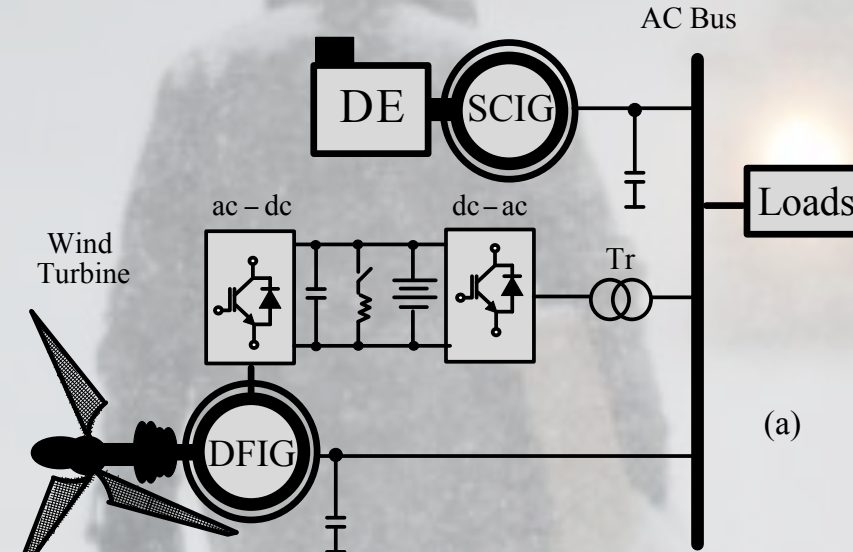

❖ POSSIBLE TOPOLOGIES IN HYBRID STANDALONE SYSTEMS

- Topologies based on fixed speed DG and variable speed WT coupled to the SCIG

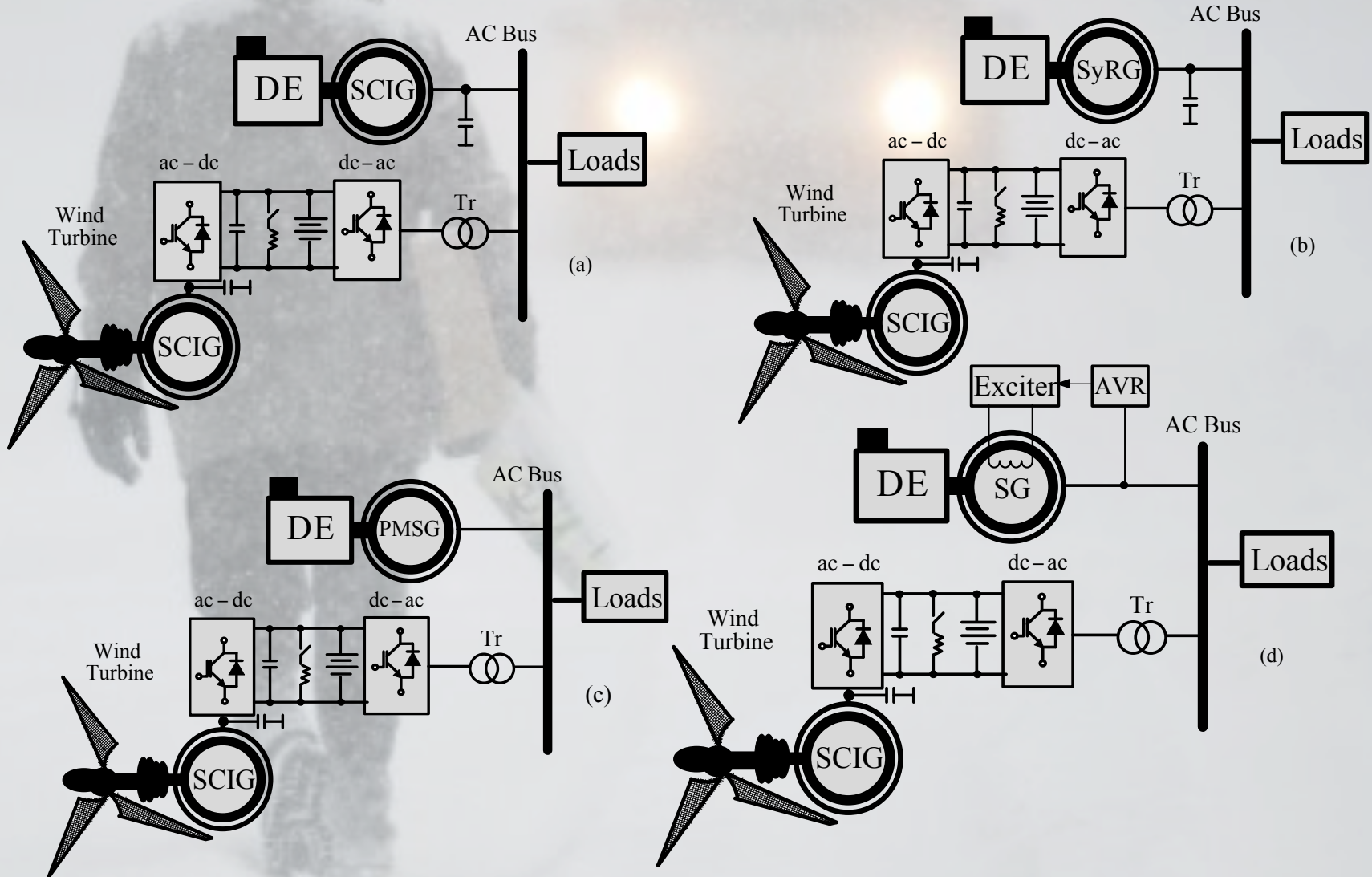

❖ POSSIBLE TOPOLOGIES IN HYBRID STANDALONE POWER GENERATION SYSTEMS

- Topologies based on fixed speed DG and variable speed WT coupled to the SG

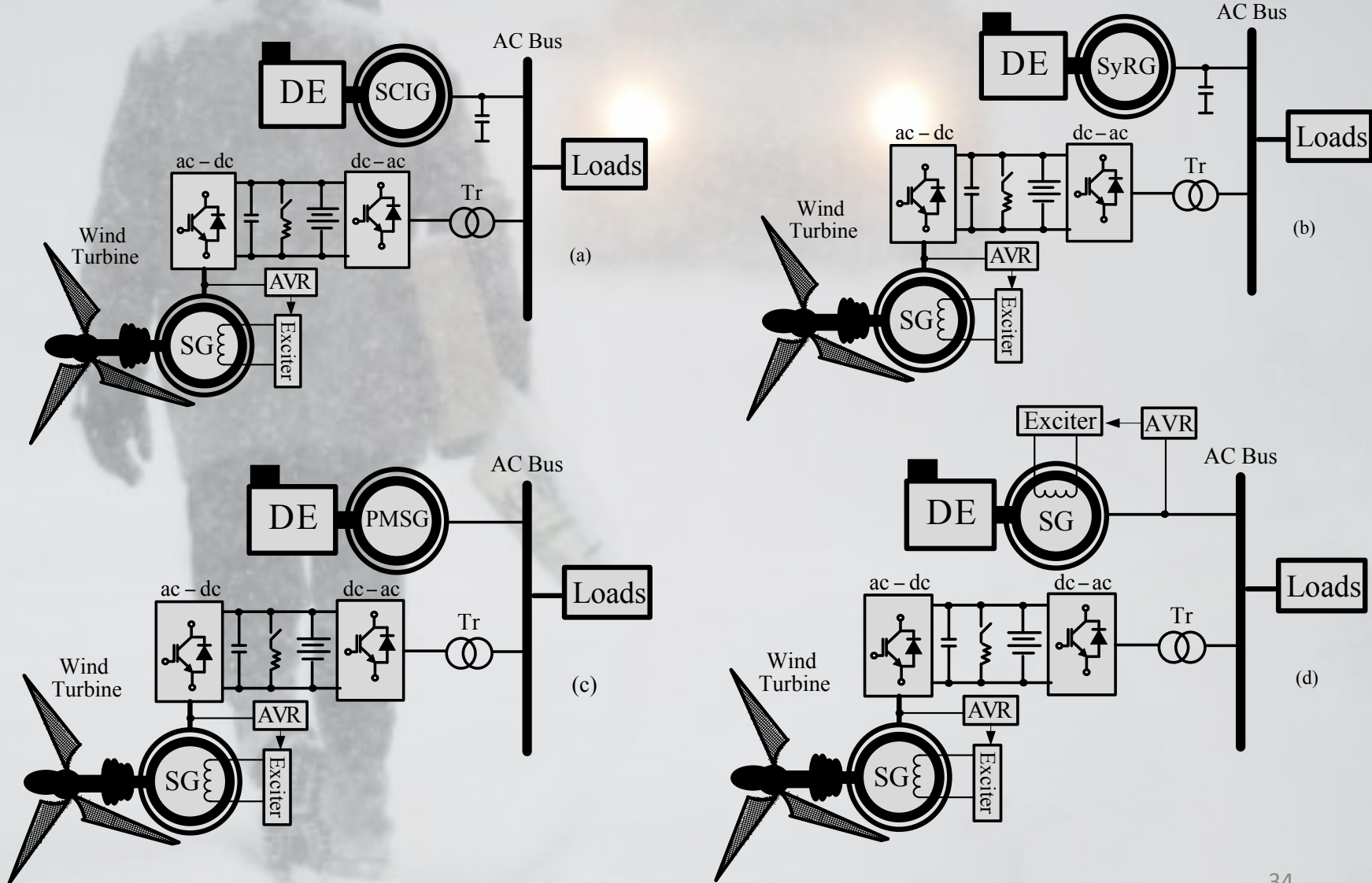

❖ POSSIBLE TOPOLOGIES IN HYBRID STANDALONE SYSTEMS

- Topologies based on fixed speed DG and variable speed WT coupled to the PMSG

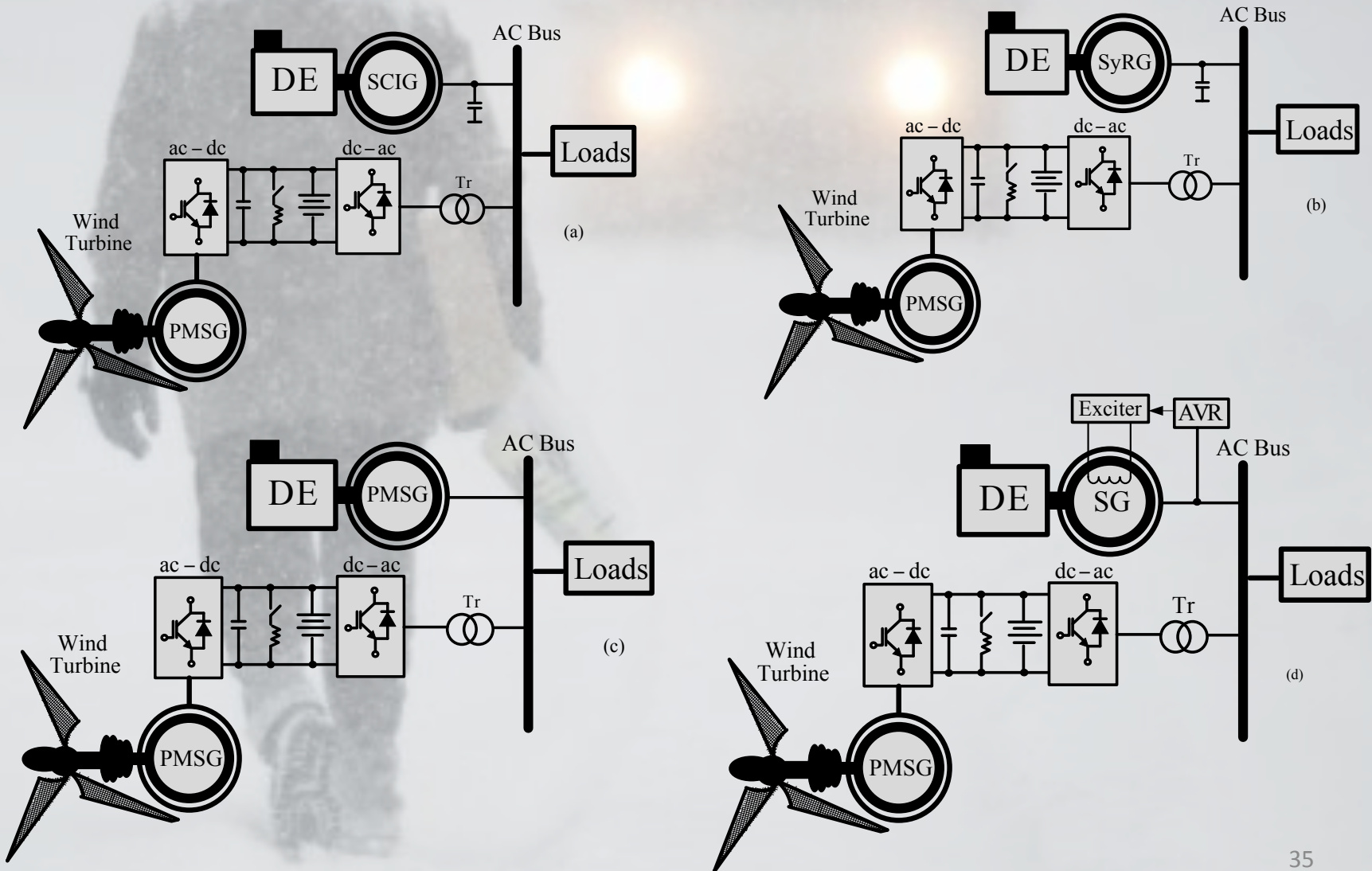

❖ POSSIBLE TOPOLOGIES IN HYBRID STANDALONE POWER GENERATION SYSTEMS

- Topologies based on fixed speed DG and variable speed WT coupled to the SyRG

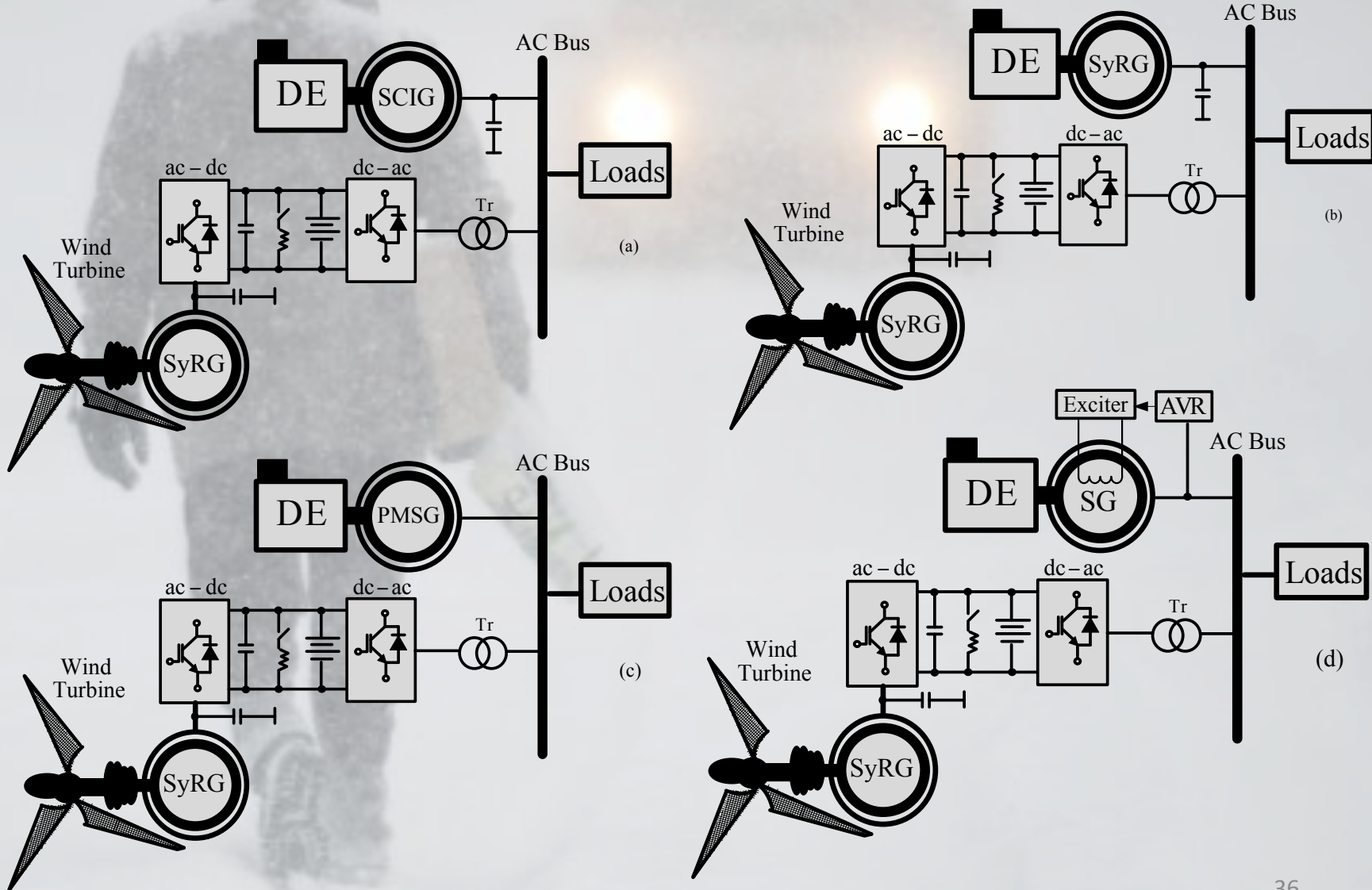

❖ POSSIBLE TOPOLOGIES IN HYBRID STANDALONE POWER GENERATION SYSTEMS

- Topologies based on variable speed DG and variable speed WT coupled to the DFIG

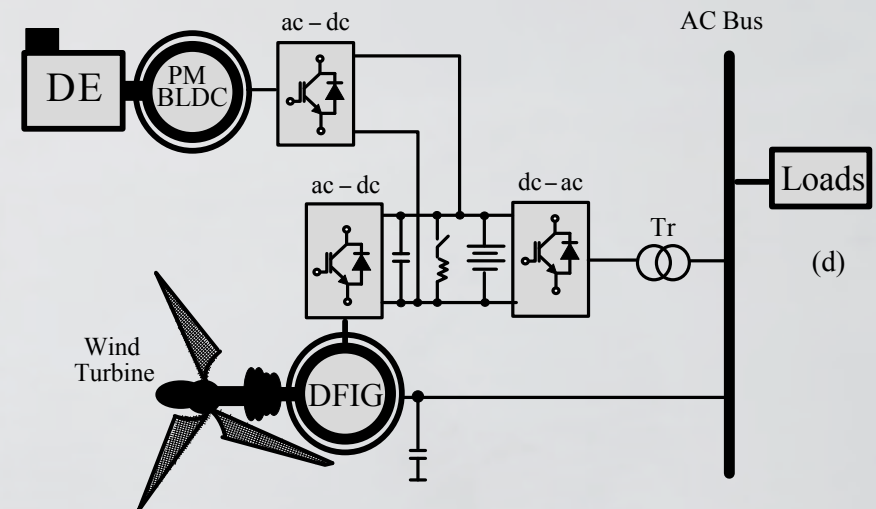
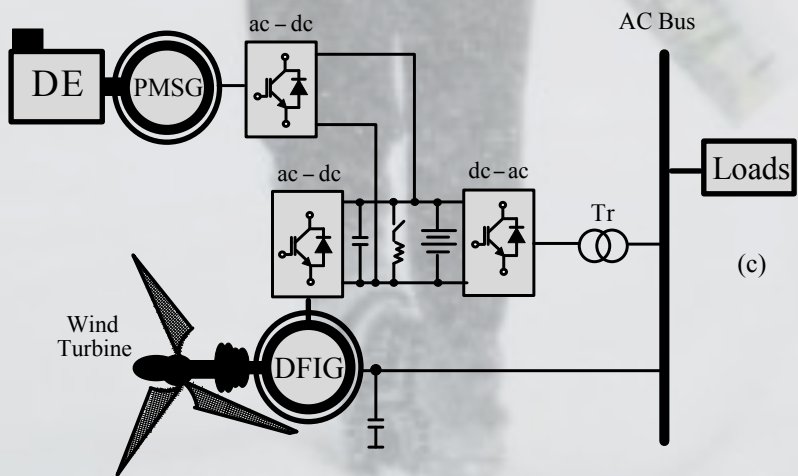
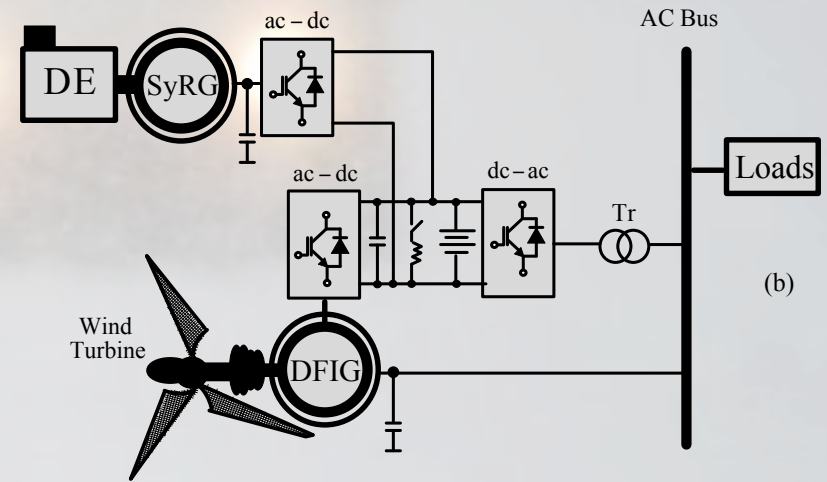
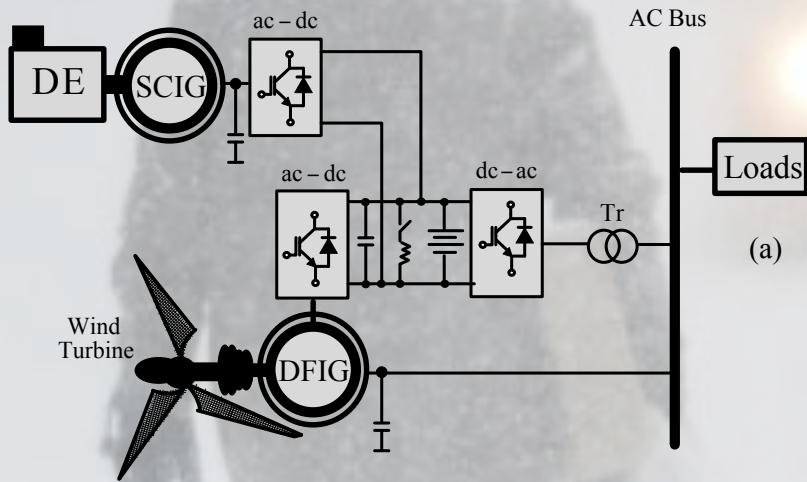

❖ POSSIBLE TOPOLOGIES IN HYBRID STANDALONE POWER GENERATION SYSTEMS

- Topologies based on variable speed DG and variable speed WT coupled to the DFIG

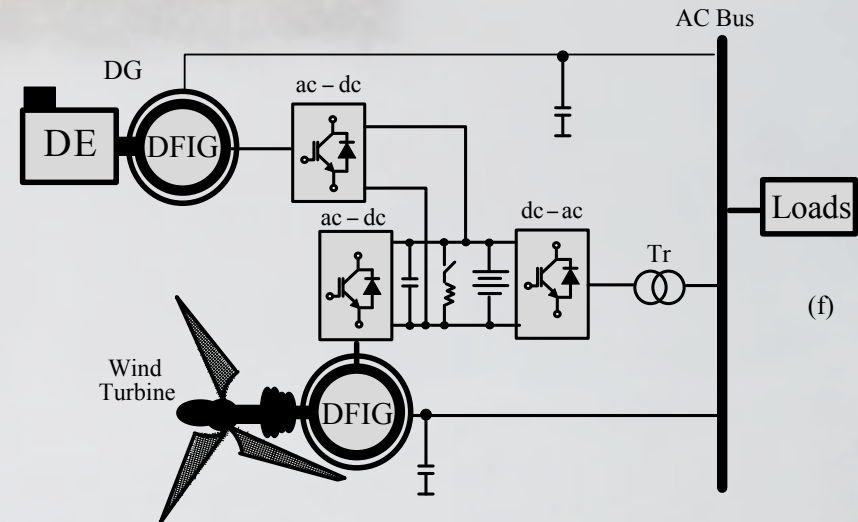
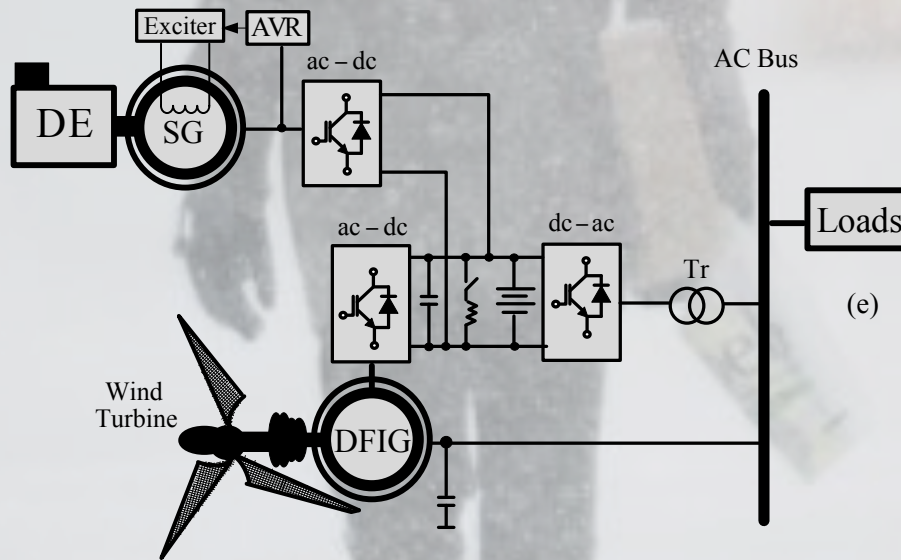

❖ POSSIBLE TOPOLOGIES IN HYBRID STANDALONE POWER GENERATION SYSTEMS

- Topologies based on fixed speed DG and variable speed WT coupled to the DFIG and solar PV array

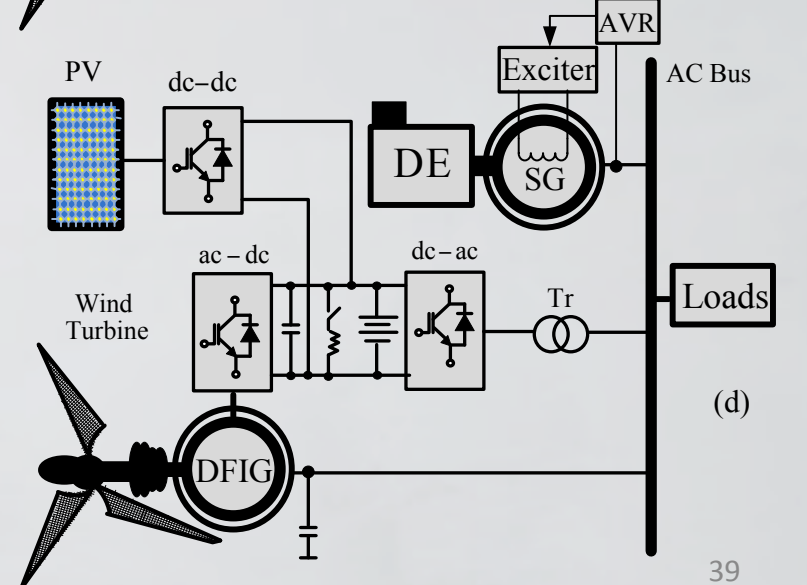
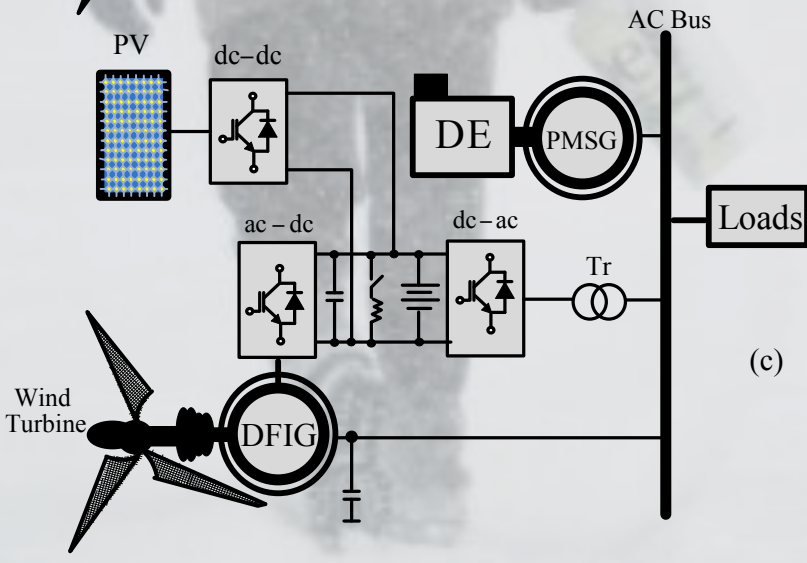
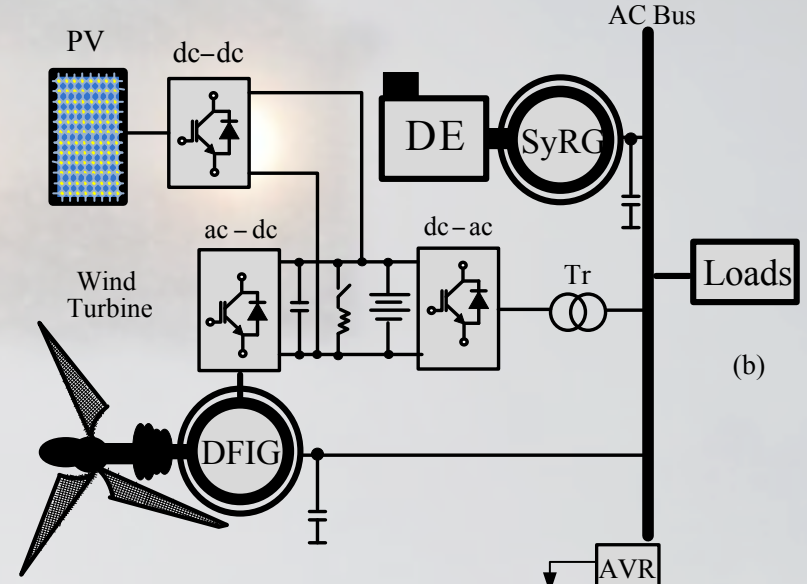
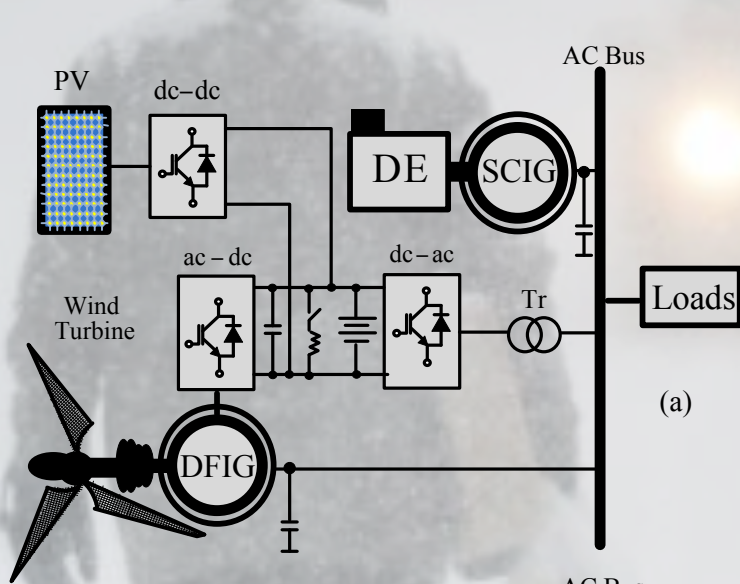

❖ POSSIBLE TOPOLOGIES IN HYBRID STANDALONE POWER GENERATION SYSTEMS

- Topologies based on variable speed DG and variable speed WT coupled to the DFIG and solar PV array

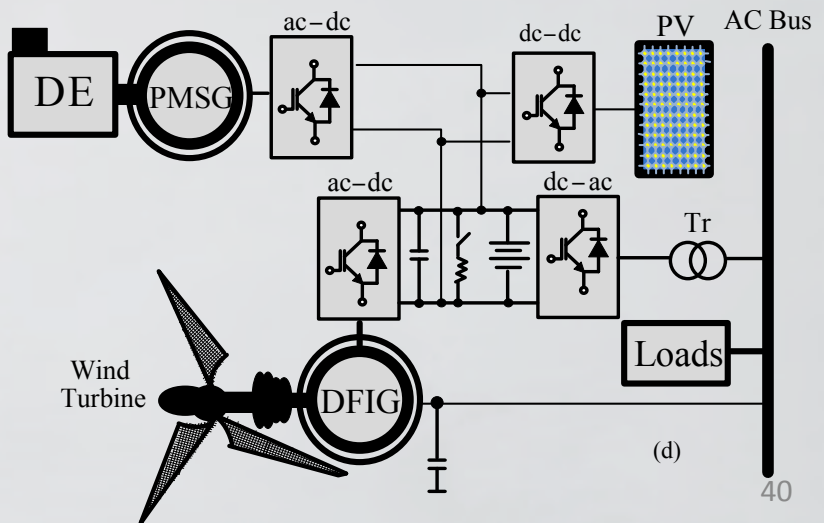
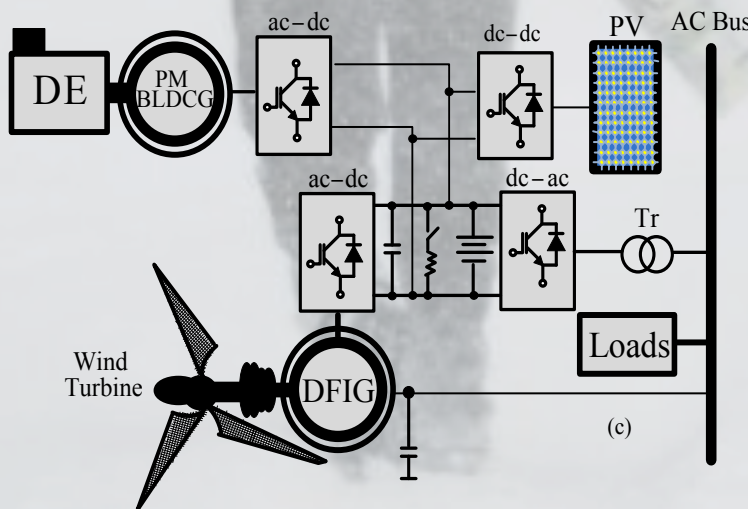
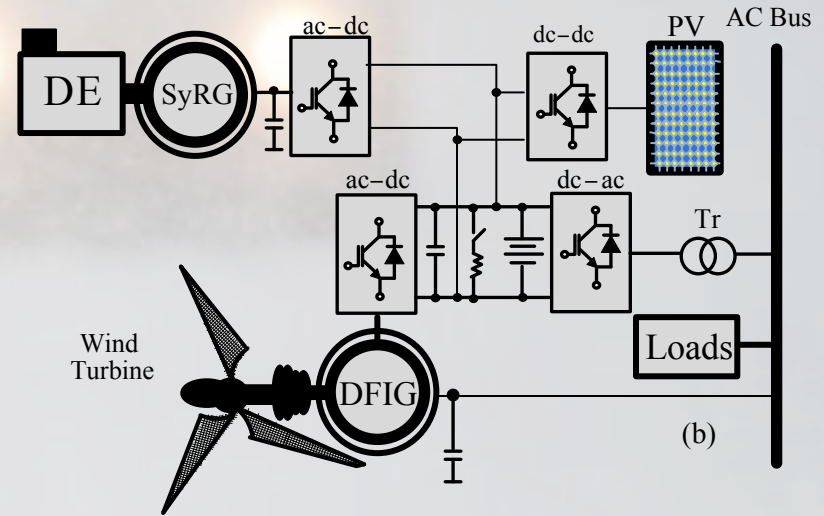
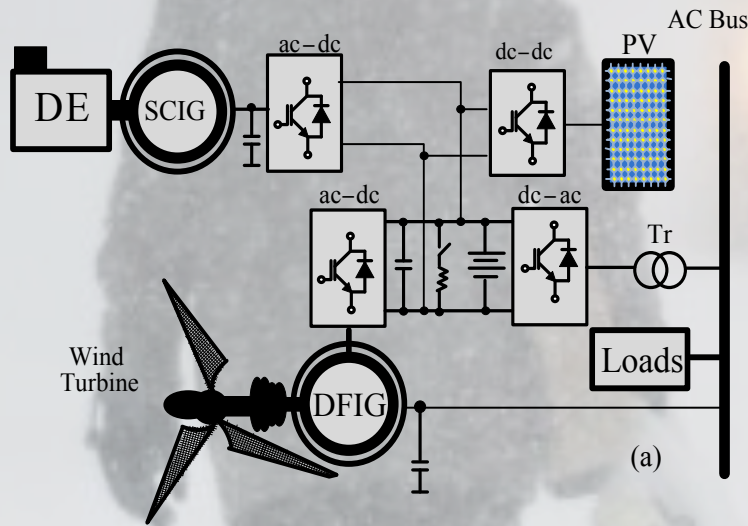

❖ POSSIBLE TOPOLOGIES IN HYBRID STANDALONE POWER GENERATION SYSTEMS

- Topologies based on variable speed DG and variable speed WT coupled to the DFIG and solar PV array

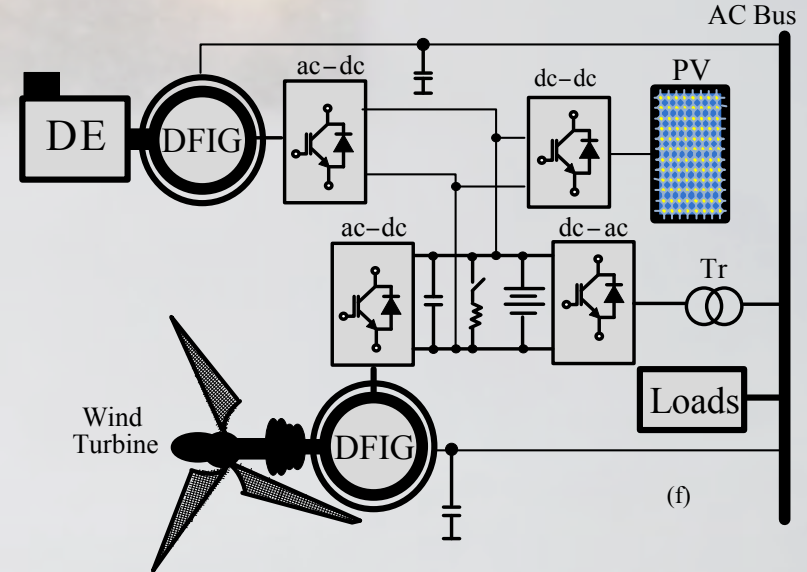
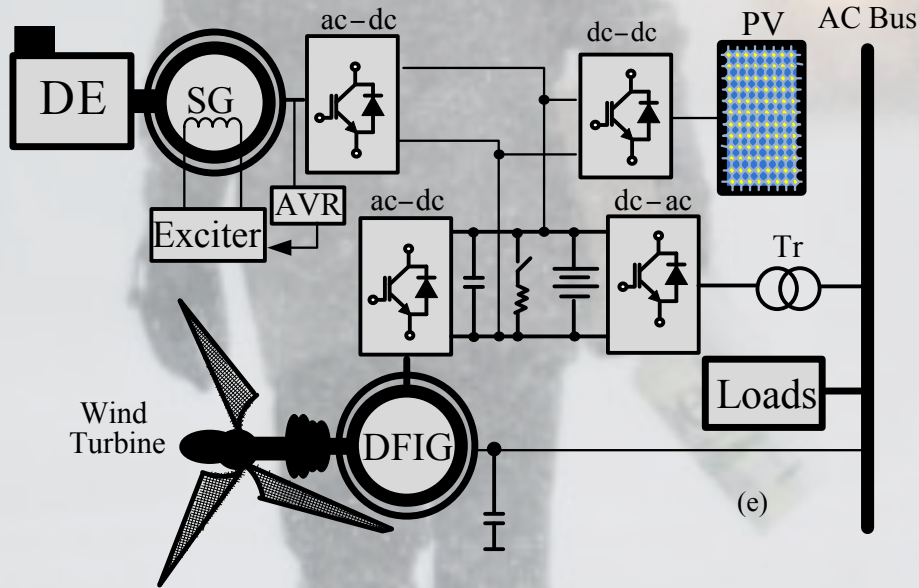

❖ POSSIBLE TOPOLOGIES IN HYBRID STANDALONE POWER GENERATION SYSTEMS

- Hybrid wind-diesel-PV-Fuel cell system based on variable speed generators

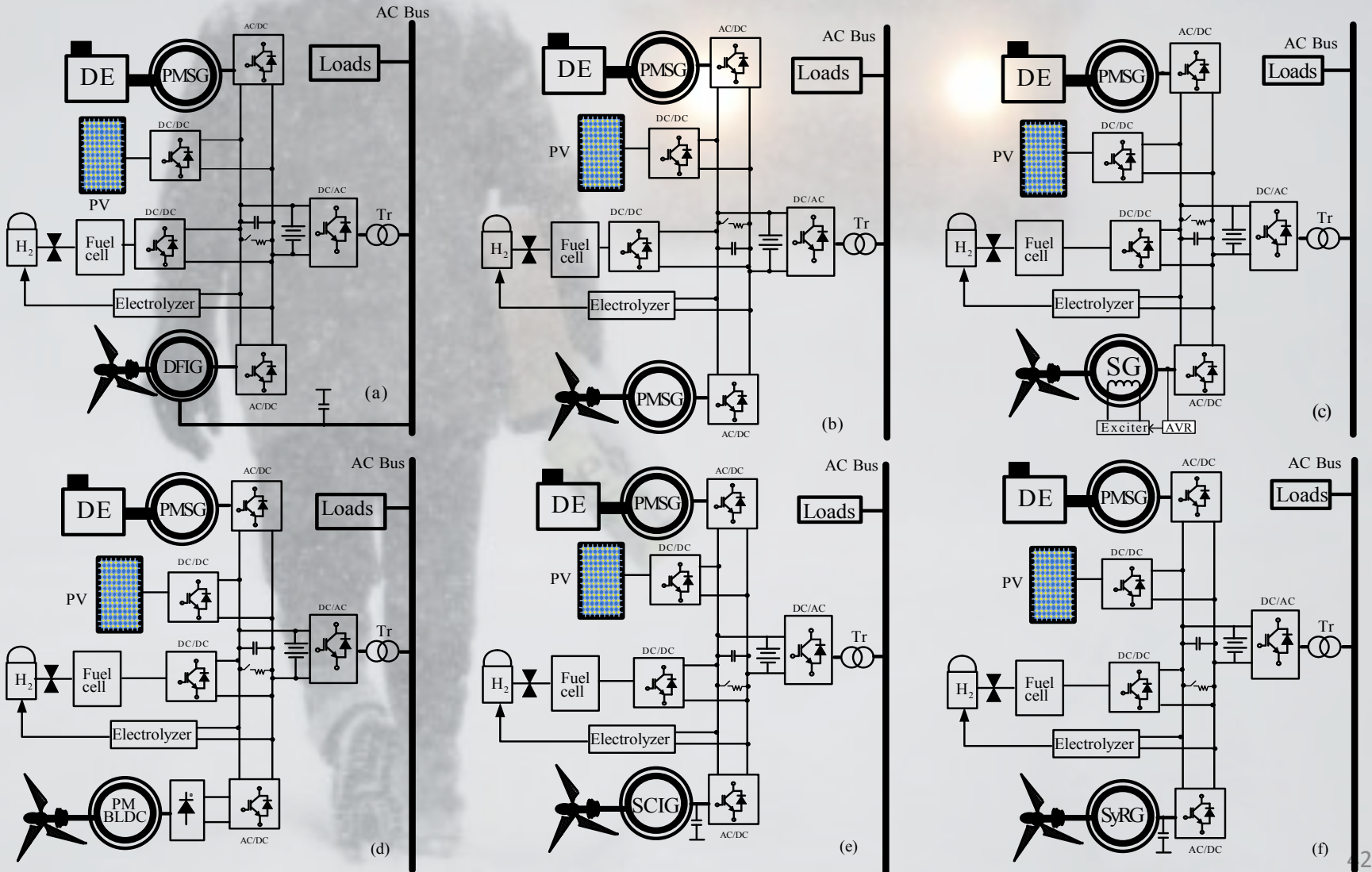

❖ POSSIBLE TOPOLOGIES IN HYBRID STANDALONE POWER GENERATION SYSTEMS

- Hybrid wind-diesel-PV-Fuel cell-micro hydro system based on variable speed generators

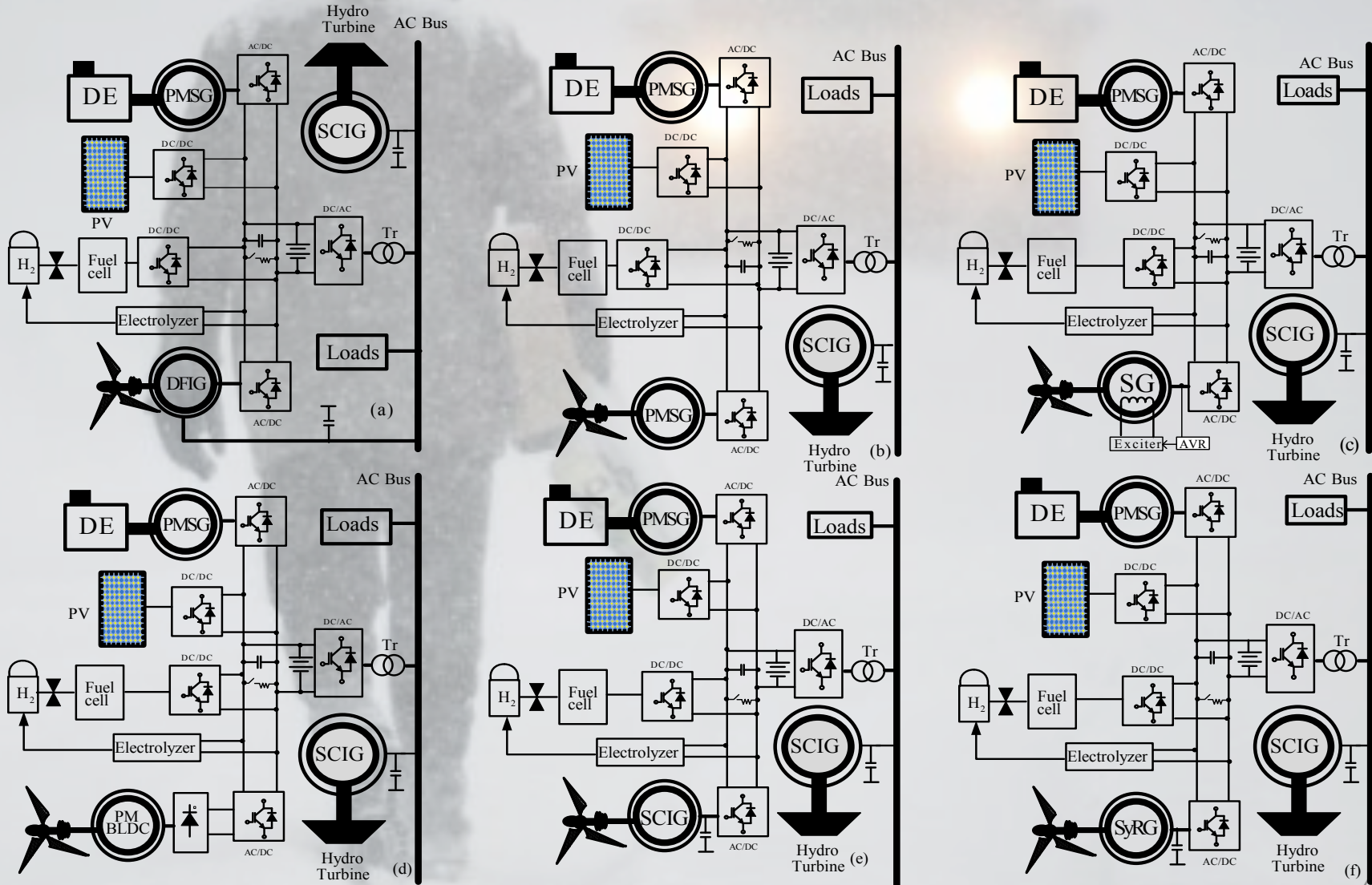

CONCLUSIONS

1. Electric power supply to many isolated regions of north Canada is presently being managed by DGs. Efforts are being made to integrate renewable energy sources to reduce fuel consumptions.
2. Stand-alone Wind Energy Conversion systems with battery are suitable alternatives for small and medium power demand applications.
3. To increase the efficiency of diesel engines, variable speed diesel engines are now available in the market, but further research work is being done to promote various high efficiency topologies of electrical generator systems.
4. Researchers are attempting around the world to develop cheaper, light weight, more efficient electrical machines and to reduce the dependance on parmanent magnet material.

CONCLUSIONS

5. In near future, with the development of proper technology, DC micro grids might be a more logical solution.
6. Performance of the proposed solution for mine site based on simulation studies and its developed control algorithms has been demonstrated for MPPTs, AC voltage and system frequency regulation, Uninterruptible power supply with high power quality, BESS protection from the overvoltage, DGs and PCC synchronization, Reactive power compensation and load balancing.
7. Many combinations of hybrid renewable energy systems are being researched and developed with promising results. Depending on the availability of the natural resources and the budget, engineers in particular region of the world have to take their own decisions to chose a suitable combination.

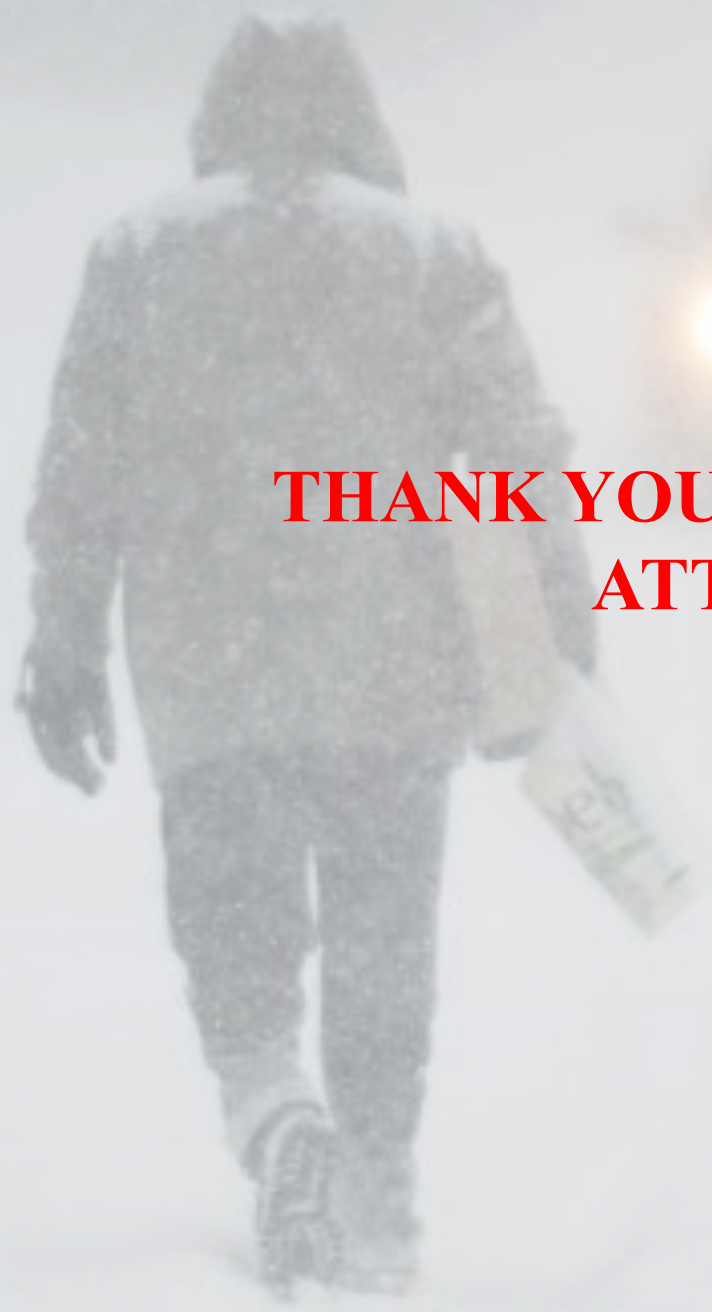

**THANK YOU FOR YOUR KIND
ATTENTION**